

Data sheet

AS-06



Arc-Series

Architectural Sound Design.





Fohhn® AS-06
Ultra-compact Subwoofer system, 150 W, 6,5" long excursion bass driver in bassreflex enclosure with Non-Turbulent-Portdesign (NTP).

Description

The Fohhn® AS-06 is an ultra compact bass system, 150 W, 6,5" long excursion bass driver in bassreflex enclosure with Non-Turbulent-Portdesign (NTP), approx. 8 kg. Fohhn® subwoofer systems are characterised by their clear, powerful reproduction of bass frequencies. All models are fitted with top-quality speakers. The compact housings are made from high-quality multiplex and are available in all RAL-colours.

Optional versions

Optional special weatherproof plastic coating.
 All RAL colours.

Connections

2x 4-pin terminal.

Mounting brackets

AS-12 Set - Set of 4x L-brackets for simply and flexible ceiling and wall mounting of the subwoofer.

Technical specifications

AS-06

electro-acoustical features

Acoustic design	vented design, NTP (Non-Turbulent Portdesign)
Components	1x 6,5" long excursion
Power rating	150W
Maximum SPL	112 dB
Frequency range	40 Hz - 500 Hz
Nominal impedance	4 ohms

features

Enclosure	multiplex birch plywood
Protection grille	steel, ball impact resistant, powder coated
Rigging points	6x M6 thread
Connections	2x 4-pin terminal
Standard colour	black, textured paint
Front design	acoustically transparent foam in enclosure colour
Dimensions (W x H x D)	approx. 30 x 21 x 38 cm
Weight	approx. 8 kg

optional features

Optional colours	all RAL colours
Weather resistance	scratch-proof polyurethane coating, impregnated speaker membranes

The manufacturer reserves the right to make technical modifications according to legal regulations stipulating the continual improvement of product features.

Fig.: Frequency response

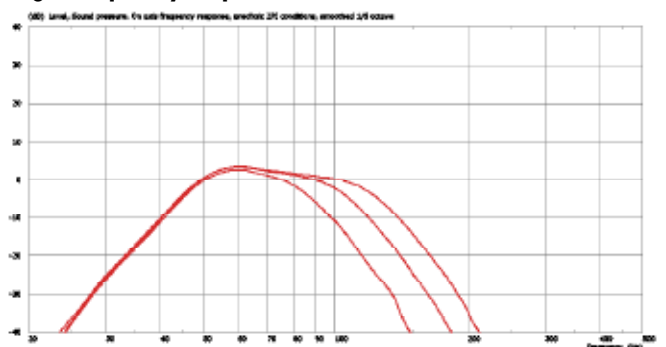

Controlling Linea-Series speakers

1. Fohhn system DSP amplifiers

Fohhn offers a range of specially adapted system DSP amplifiers for controlling Arc speaker systems, which guarantee maximum sound performance and operational reliability for your Fohhn products. As manufacturers of speaker, amplifier and DSP technology, we know our systems inside and out right down to the smallest detail and are therefore in a perfect position to provide our users with the best overall system.

Fohhn System DSP amplifier are offering following advantages:

Integrated high-performance DSP technology:

- quick set-up,
- minimal space requirements in electronics cabinet,
- minimal cable requirements,
- fewer cable faults,
- controller and amplifier can be controlled and monitored using the same software.

Dual DSP technology

The DSP amplifiers contain 2 separate DSP engines with enormous capacity and processing power for 5 digital audio devices (DSP-1) and Fohhn specific speaker databases (DSP-2).

Remote monitoring and control

Integrated temperature and operating time monitor, status indicator / protection, remote control capability / network compatibility using a laptop, wall installation modules or media control systems.

Fohhn® dual DSP technology

DSP-1: Integrated digital audio devices

Each amplifier channel has a:

- programmable 10 band parametric EQ,
- compressor/limiter/noise gate,
- delay,
- X-over function,
- top-quality pink noise and sweeptone generator

DSP-2: Speaker management

An integrated speaker database guarantees excellent sound quality and protection for all Fohhn speaker types. A sophisticated algorithm developed by Fohhn engineers and adapted to each speaker allows the individual monitoring and adjustment of bass, mid and high ranges.

1.1 Amplifier recommendations for the Arc-Series



D-2.750

2 channel operation, 2x 750 W / 4 ohms, 2x 390 W / 8 ohms, Fohhn Audio DSP, display, remote control

D-4.750

4+2 channel operation, 4x 750 W / 4 ohms, 4x 390 W / 8 ohms
2x DSP line out channels for controlling a conventional amplifier
 Fohhn Audio DSP, display, remote control

	Arc-Tops										Linea					Arc-Subs							
	AT-05	AT-061	AT-07	AT-08	AT-09	AT-10	AT-22	AT-221w	AT-35	AT-40	AT-50	AT-661w	AL-10-150	LX-10-61	LX-100-220	LX-500/501	LX-600/601	AS-06	AS-10	AS-22	AS-31	AS-40	
D-2.750	x	x	x	x	x	x	x	x					x	x	x			x	x	x			
D-4.750	x	x	x	x	x	x	x	x					x	x	x			x	x	x			
D-2.1500									x	x	x	x			x	x	x				x	x	
D-4.1200									x	x	x	x			x	x					x	x	

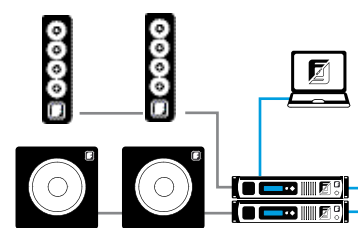

2x Sub passive / 2x Top passive
 2x DSP amplifier

Controlling Linea-Series speakers

2. Standard amplifiers combined with Fohhn controllers

Standard amplifiers / 100V amplifiers / multichannel amplifiers combined with Fohhn FC-9 DSP system controllers

All of the speaker systems in the Fohhn Arc-Series can be operated in combination with standard amplifiers (e.g. Bittner amplifiers). Each Fohhn speaker model has a linear design, neutral sound adaptation function and is fitted with an integrated crossover with electronic tweeter protection.

We recommend integrating the FC-9 Fohhn DSP system controller for applications involving standard multichannel amplifiers, 100V amplifiers or monitored amplifiers according to EN 60849.

The FC-9 guarantees maximum sound quality, operational reliability and performance features that no other standard controller can offer in combination with our Fohhn speakers.

Sound quality. Reliability. Intelligent control.

- * Fohhn DSPs guarantee maximum sound performance
- * 5 premium audio tools such as Parametric EQ are integrated
- * Integral speaker and amplifier database for maximum operating reliability
- * Remote monitoring/operation, network-compatible
- * Automatic amplifier calibration function CAS
- * 8 input switching contacts for easy system integration
- * Perfect adaptation to all standard amplifiers

FC-9 DSP system controller



Advantages of the FC-9 controller:

Perfect adaptation to all standard amplifiers

Automatic amplifier calibration function and integrated amplifier database for perfect adaptation.

Dual DSP technology

The FC-9 contains 2 separate DSP engines with enormous capacity and processing power for Fohhn specific speaker databases and 5 digital audio devices.

Integrated speaker database

Guarantees excellent sound quality and protection for all Fohhn speaker types.

A sophisticated algorithm developed by Fohhn engineers and adapted to each speaker allows the individual monitoring and adjustment of bass, mid and high ranges.

Remote monitoring and control

Remote control capability / network compatibility using a laptop, wall installation modules or media control systems.

8 input switching contacts

The FC-9 has 8 input contacts. The inputs can be utilized to switch between the different presets of the FC-9, as well as other Fohhn-Net devices. With two inputs and two pushbuttons (shutters) connected to them, a volume control can be realized as well.

4 inputs / 6 outputs (24 nodes)

A programmable 10-band parametric EQ, compressor/ limiter/noise gate, delay, X-over function, top-quality pink noise and swepttone generator are available at each output, allowing you to conveniently adapt the Fohhn system to the room acoustics or your own personal requirements.

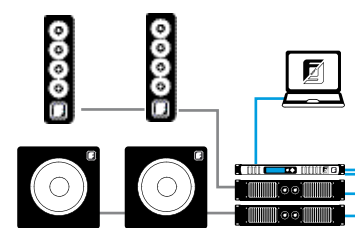

2x Sub passive / 2x Top passive
2x standard amplifiers
1x DSP system controller FC-9

Remote control and network ability of Fohhn devices with integrated DSP

FR-10

remote control wall panel designed for the remote operation of Fohhn devices with integrated DSP.



Description

The FR-10 is a wall mount remote control module designed for the remote operation of Fohhn DSP amplifiers, DSP controllers and active Fohhn speakers systems. The FR-10 is extremely easy to operate because the controls are so well arranged. It is virtually impossible for the end customer to make operating errors because the only operating elements are the 8 labelled buttons.

Easy handling

Control up to 31 Fohhn devices individually with this stylish FR-10 wall panel. 8 programmable buttons can be configured to control the overall volume of a system, the volume in different zones or presets for different room effects, for example. The system also has a special function that confirms whether all commands have been executed successfully. The buttons indicate this by changing red or green shortly after they are pressed. For example, if a device is not switched on, the button changes red to indicate that a command could not be executed. This additional monitoring function ultimately contributes to the overall operating reliability of your system. The wall panel is easy to configure using a standard computer with intuitive Fohhn-Net Remote software installed.

Connections

Two terminal strips (paralleled). Alternative connection via standard 4-wire telephone cable.

Applications

The FR-10 is ideal for training rooms, hotels, churches, halls, restaurants or any venue where a simple, efficient system is required to control your audio equipment from a central location.

The FR-10 is also ideal for projects where complex media control systems are not viable or inappropriate, but the user wishes to control the speaker system centrally.

FR-20

19" remote control unit can be controlled via conventional external buttons or switches.



Description

The FR-20 can be controlled via conventional external buttons or switches (e.g. Jung, Vitra, etc.) or switching contacts (e.g. media control system). Buttons and switches may come in the form of a wall installation module or an individually manufactured control panel, for example.

Presets stored in the connected Fohhn DSP devices are activated simultaneously and settings for different scenarios such as speech, music, empty room, full room, etc are loaded when the buttons/switches are pressed. You can also adjust the volume quickly and easily in 1 dB increments using the FR-20. A maximum of 31 Fohhn devices connected to the network can be activated simultaneously at the press of a single button.

Integration in a media control system

The FR-20 allows the convenient integration of all DSP-controlled Fohhn devices into media control systems (e.g. AMX, Crestron) by means of 8 switching contacts or RS-485 interface.

Integration in a EIB bus technology

One building, one concept, one system.

Fohhn systems equipped with a FR-20 distribution switch comply with the „European installation bus technology“ standard, including all operating comforts.

Applications

The FR-20 is ideal for training rooms, hotels, churches, halls, restaurants, clubs, bars and many other venues.

For simple, reliable remote operation of your audio system without having to install complex, expensive media control systems.



Accessories for AS-06

VAS-12

VAS-12 Set - Set of 4x L-brackets for simply and flexible ceiling and wall mounting of the subwoofer.

Variation 1

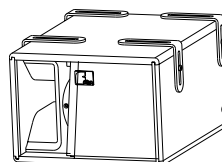

Variation 2

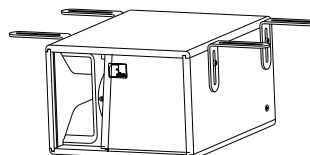

Variation 3

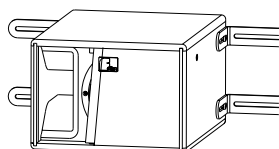

Variation 4

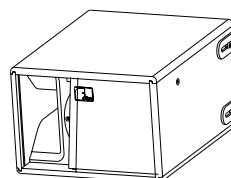

Views of AS-06

Front view

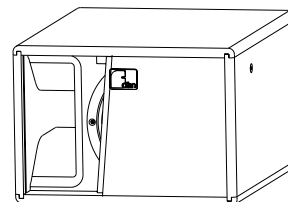
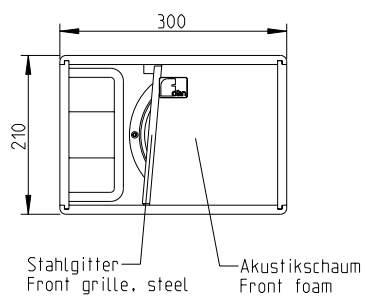

Side view

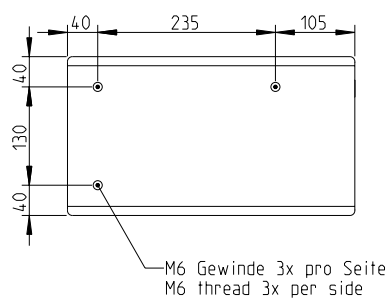

Top and Bottom View

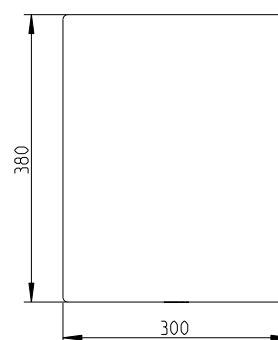

Rear view

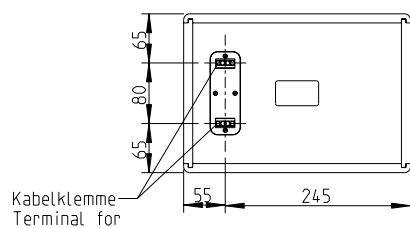

Mounting brackets VAS-12 for AS-06

Front view variation 1

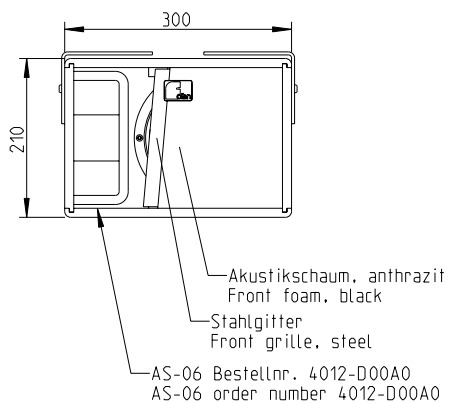

Rear view variation 1

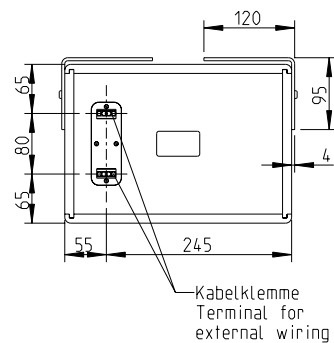

Top view variation 1

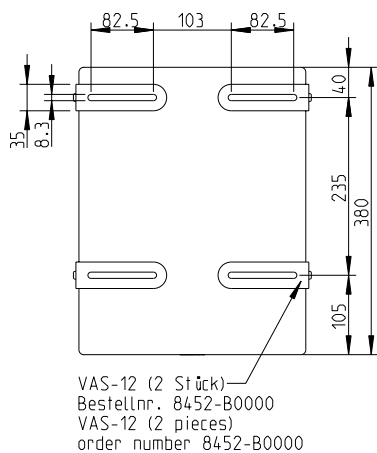

Side view variation 1

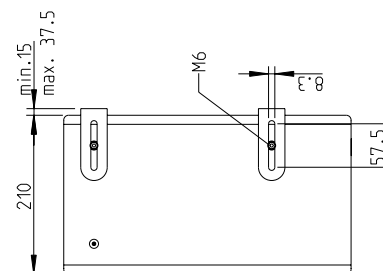

Top view variation 2

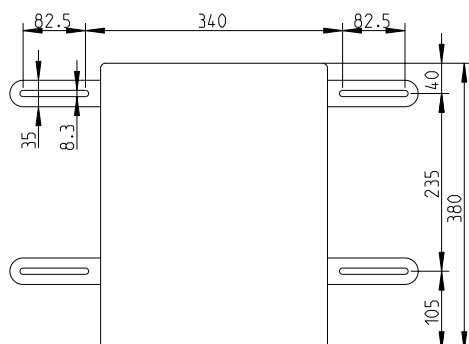

Side view variation 2

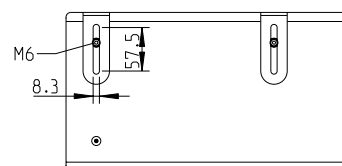

Mounting brackets VAS-12 for AS-06

Front view variation 3

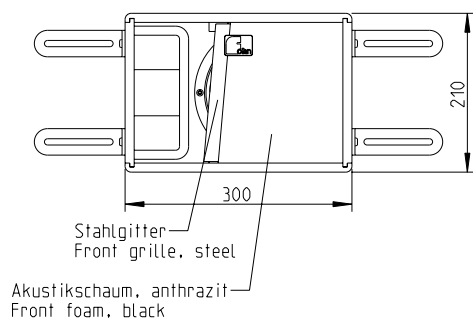

Rear view variation 3

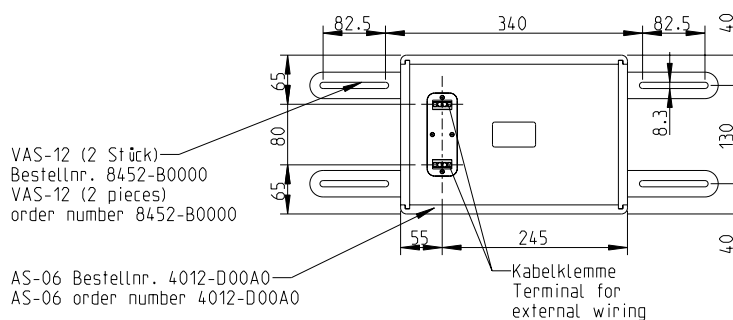

Side view variation 3

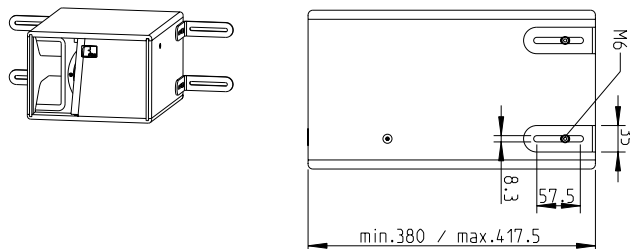

Rear view variation 4

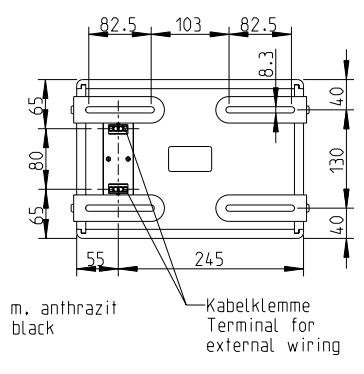

Side view variation 4

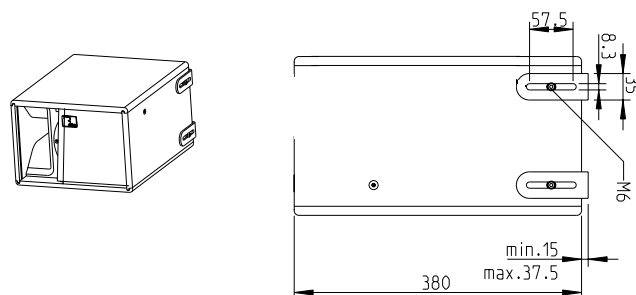

Tender specifications

Ultra compact 6,5" high power low frequency system

Small and very compact Subwoofer using one 6,5"-long excursion bass driver in a bassreflex enclosure with Non-Turbulent Port design. Highly precise and powerful low frequency sound reproduction at smallest speaker dimensions. High quality multiplex birch plywood enclosure with scratch resistant textured paint. Optionally available in all RAL-colours. Ball impact proof front cover protection grille with acoustically transparent foam. Connection via 2x 4pin Varicon terminal. Optionally available VAS-12 wall mount bracket.

Technische Daten:

electro-acoustical features:

acoustic design:	vented design, NTP (Non-Turbulent Port design)
components:	1x 6,5" long excursion
power rating:	150 W
maximum SPL:	112 dB
frequency range:	40 Hz - 500Hz
nominal impedance:	4 ohms

features:

enclosure:	multiplex birch plywood
protection grille:	steel, ball impact resistant, powder coated
rigging points:	6x M6 thread
connections:	2x 4-pin terminal
standard colour:	black, textured paint
front design:	acoustically transparent foam in enclosure colour
dimensions (W x H x D):	approx. 30 x 21 x 38 cm
weight:	approx. 8 kg

optional features:

optional colours:	all RAL colours
weather resistance:	scratch-proof polyurethane coating, impregnated speaker membranes

brand:	Fohhn Audio AG
model:	AS-06

FOHNN.
SOUNDS PERFECT.
IS PERFECT.

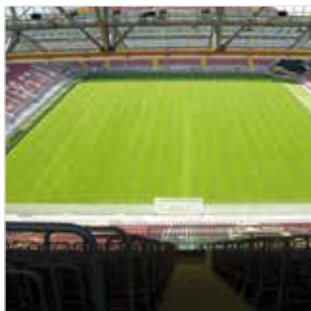

■ German quality
■ engineered and made
■ by Fohhn®

Fohhn Audio AG
Hohes Gestade 3-8
72622 Nürtingen
Germany
Tel. +49 7022 93323-0
Fax +49 7022 93324-0
www.fohnn.com
info@fohnn.com