



# USER MANUAL

# AX1012A

## powered constant curvature array element

### KEY FEATURES

- 12" woofer, 1.4" HF neodymium compression driver
- Constant curvature Seamless Transition Waveguide (SWT) with 20° H x 100° V dispersion
- Class D amplifier module with SMPS
- 96KHz / 40 bit floating point CORE processing with PRONET remote control
- Integral suspension hardware for horizontal or vertical array installation
- Pole mounting available for free-standing applications

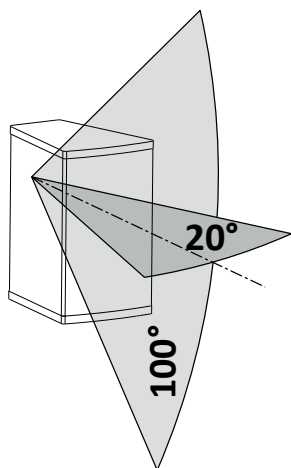

### INTRODUCTION

AX1012A is a versatile constant curvature full-range element that can be used to create both vertical and horizontal line source arrays and also as a high-directivity point-source loudspeaker.

The 1.4" high frequency compression driver is coupled to STW - Seamless Transition Waveguide, which ensures a precise control of mid-high frequencies both on horizontal and vertical axis, for a perfect acoustic coupling between the enclosures that form the array. The unique waveguide design produces vertical line source directivity with a horizontal pattern that is maintained down to approximately 950Hz. This allows to project clean music and vocals evenly around the audience without hot-spots and dead-spots. The sharp SPL off-axis rejection is used to avoid reflecting surfaces in the enclosure coupling plane and perfectly adjusts the acoustic coverage to the audience geometry.

The AX1012A tour-grade 15mm phenolic birch plywood cabinet is fitted with four integrated steel rails, to be used for coupling the cabinets with the KPTAX1012 aluminium coupling bars. A comprehensive set of accessories is available for creating horizontal or vertical arrays, for ground-stacking the systems and also for pole mounting one unit.

AX1012A is recommended for the use as indoor FOH (Left - Centre - Right systems) or outdoor FOH in small to medium-sized events. It can be used also as a complement to large systems as Out-fill, In-fill or distributed fill

applications in a wide range of venue, providing clear sound to areas not fully reached by the main system, while minimizing unwanted interactions and room reflections.

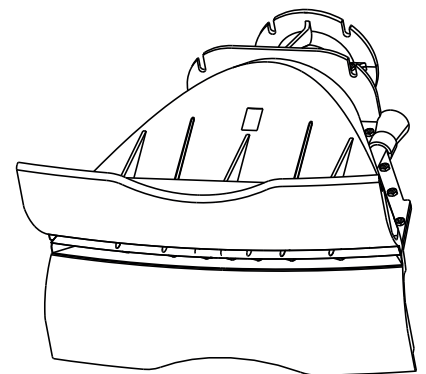

### TECHNICAL SPECIFICATIONS

Acoustical		Remote Controls	PRONET control software
System type	Constant Curvature Array Element	Network protocol	CANBUS
Low frequency transducer	12" (305 mm) LF driver, 3" (75 mm) ISV aluminium voice coil, 4Ω	Amplifier Type	Class D amplifier with SMPS
High frequency transducer	1.4" (35.5 mm) HF compression driver, 2.4" (61 mm) aluminium voice coil, Titanium diaphragm, 8Ω	Output Power	900W + 300W
Frequency response (-6 dB)	65 Hz – 17 kHz (Processed)	Mains Voltage Range (Vac)	230 V~ ±15% or 115 V~ ±15% 50/60 Hz
Horizontal Coverage Angle (-6 dB)	20° (1KHz-17KHz)	Mains Connector	PowerCon® (NAC3MPA + NAC3MPB)
Vertical Coverage Angle (-6 dB)	100° (1KHz-17KHz)	Consumption*	575 W (nominal) 1200 W (max)
Maximum Peak SPL @ 1m	134 dB	IN / OUT Connectors	Neutrik XLR-M / XLR-F
<b>Electrical</b>		IN / OUT Network Connectors	ETHERCON® (NE8FAV)
Input Impedance	20 kΩ balanced	<b>Mechanical</b>	
Input Sensitivity	+4 dBu / 1.25 V	Width	370 mm (14.6")
Signal Processing	CORE processing, 96kHz / 40bit floating point SHARC DSP, 24 bit AD/DA converters	Height	611 mm (24")
Direct access Controls	4 Presets: Single, Mid-Throw, Long-Throw, User. Network Termination, GND Link	Depth	495 mm (19.5")
		Taper angle	10°
		Construction	15mm, reinforced phenolic birch
		Paint	High resistance, black water based paint
		<b>Rigging system</b>	
		Suspension	Captive suspension system
		Net Weight	34.5 Kg (76.1 lbs)

\* Nominal consumption is measured with pink noise with a crest factor of 12 dB, this can be considered a standard music program.





**MECHANICAL DRAWING**

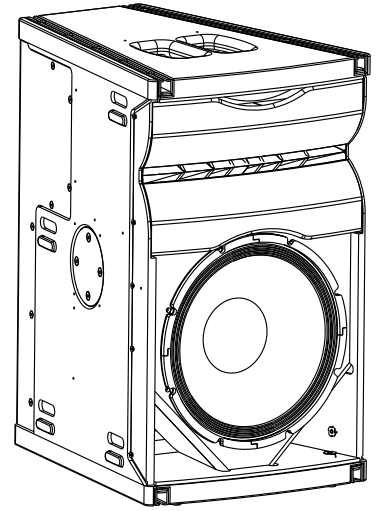
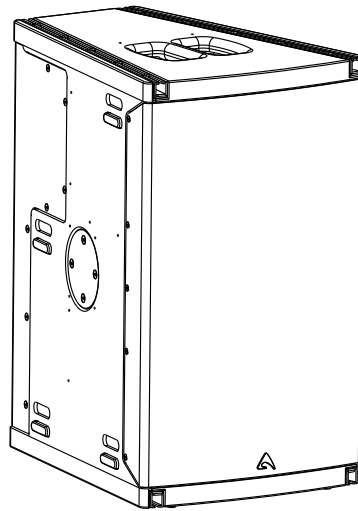
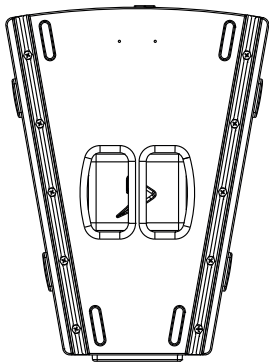
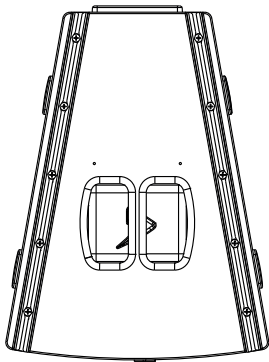
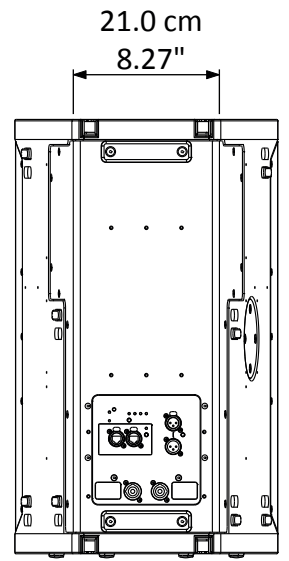
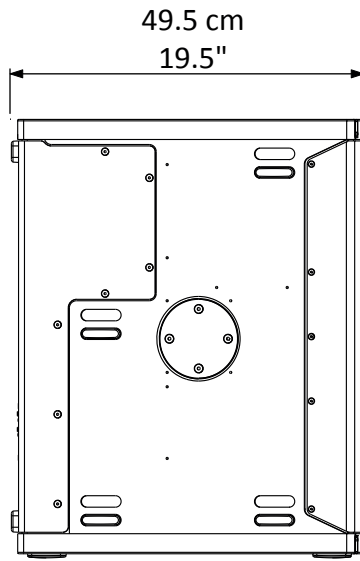
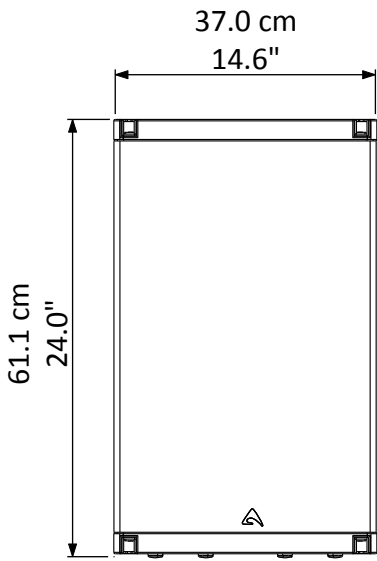

**SPARE PARTS**

**NAC3MPA**

Neutrik Powercon® BLUE SOCKET

**98ED120WZ4**

12" woofer - 3" VC - 4 ohm

**NAC3MPB**

Neutrik Powercon® WHITE SOCKET

**98DRI2065**

1.4" - 2.4" VC compression driver - 8 ohm

**91AMD1012A**

Power amplifier module with mechanical assembly

**98MBN2065**

titanium diaphragm for 1.4" driver





## RIGGING ACCESSORIES

**KPTAX1012**      **Coupling bar**  
weight = 0.75 Kg

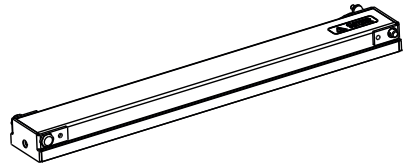

**KPTAX1012H**      **Horizontal array flying bar**  
weight = 0.95 Kg  
note: the bar is supplied with 1 straight shackle.

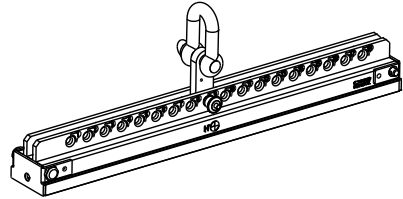

**KPTAX1012T**      **Suspension bar**  
weight = 2.2 Kg  
note: the bar is supplied with 3 straight shackles.

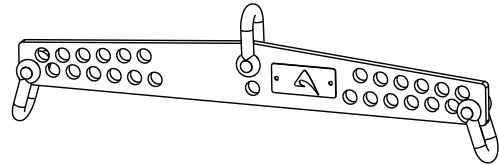

**KPTAX1012V**      **Vertical array flying bar**  
weight = 8.0 Kg  
note: the bar is supplied with 1 straight shackle.

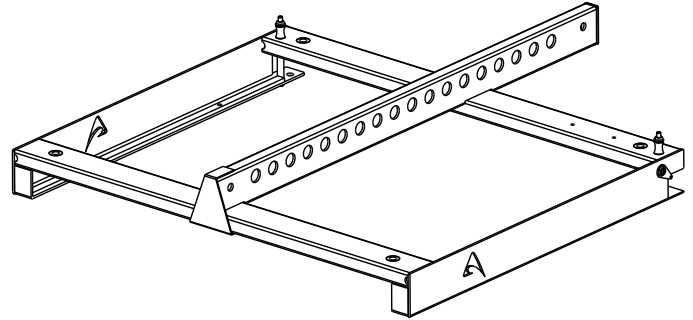

## OTHER ACCESSORIES

**KPAX265**      **Pole adapter**  
note: use it always in conjunction with tilt adapter

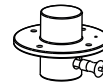

**KP010**      **Tilt adapter**

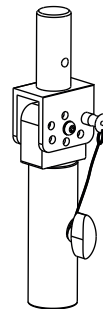

**PLG714**      Straight Shackle 14 mm for Fly bar weight = 0.35 Kg



**AXFEETKIT**      Kit of 6pcs BOARDACF01 M10 foot for stacked installation

**DHSS10M20**      Adjustable Sub-Speaker ø35mm spacer with M20 screw

**94SPI85770**      8x63 mm Locking Pin (used on KPTAX1012, KPTAX1012H, KPTAX1012T)

**94SPI826**      8x22 mm Locking Pin (used on KPTAX1012H)

**USB2CAN-D**      PRONET network converter

see <http://www.axiomproaudio.com/> for detailed description and other available accessories.





## I/O AND CONTROL OPERATIONS

**MAINS IN** - Powercon® NAC3FCA power input connector (blue). To switch the amplifier on, insert the Powercon® connector and turn it clockwise into the ON position. To switch the amplifier off, pull back the switch on the connector and turn it counter-clockwise into the POWER OFF position.



**WARNING!** In the case of product failure or fuse replacement, disconnect the unit completely from the mains power. The power cable must be only connected to a socket corresponding to the specifications indicated on the amplifier unit. The power supply must be protected by a suitably rated thermo-magnetic breaker. Preferably use a suitable switch to power on the whole audio system leaving the Powercon® always connected to each speaker, this simple trick extend the life of the Powercon® connectors.

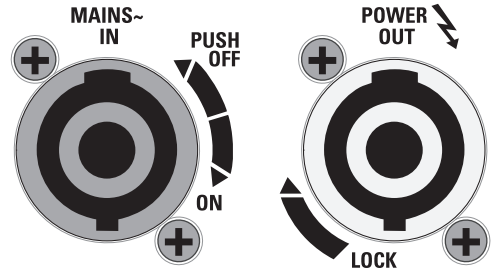

**MAINS OUT** - Powercon® NAC3FCB power output connector (grey). This is connected in parallel with the MAINS ~ / IN. The maximum load applicable depends on the mains voltage. With 230V~ we suggest to link a maximum of 5 AX1012A loudspeakers, with 120V~ we suggest to link a maximum of 3 AX1012A loudspeaker.

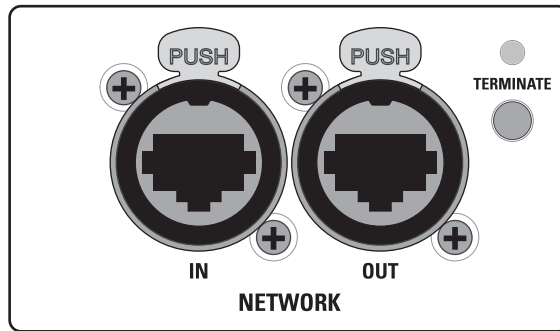
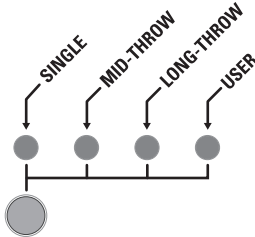

**INPUT** - Audio signal input with locking XLR connector. It has a fully electronically balanced circuitry including AD conversion for the best S/N ratio and input headroom.

**LINK** - A direct connection from the input connector to link other speakers with same audio signal.

**ON** - This LED indicates power on status.

**SIGN/LIMIT** - This LED lights in green to indicate the presence of the signal and lights in red when an internal limiter reduces the input level.

**GND LIFT** - This switch lift the ground of the balanced audio inputs from the earth-ground of the module.

**PRESET BUTTON** - This button has two functions:

1) Pressing it while powering on the unit:

**ID ASSIGN** the internal DSP assigns a new ID to the unit for the PRONET remote control operation. Each loudspeaker must have a unique ID to be visible in the PRONET network. When you assign a new ID, all the other loudspeakers with the ID already assigned must be ON and connected to the network.

2) Pressing it with the unit ON you can select the DSP PRESET. The selected PRESET is indicated by the corresponding LED:

**SINGLE** Suited for a typical use of a single loudspeaker on a pole, standalone or in combination with a subwoofer, or in a front fill application.

**MID-THROW** Suited for the use of the loudspeakers in an array configuration when the distance between the array centre and the audience area is about 25mt or less.

**LONG THROW** Suited for the use of the loudspeakers in an array configuration when the distance between the array centre and the audience area is about 40mt.

**USER** This LED lights when the USER PRESET is loaded. This preset corresponds to USER MEMORY no. 1 of the DSP and, as a factory setting, it's the same as SINGLE. If you want to modify it, you must connect the unit to a PC, edit the parameters with PRONET AX control software and save the PRESET in the USER MEMORY no. 1. *Note: see also the PRONET AX example further in this manual.*



**IMPORTANT NOTE:** The AX1012A system is conceived as a CONSTANT CURVATURE ARRAYS loudspeaker so ALL AX1012A units that belong to the same array must be have the same PRESET to work well together.

**NETWORK IN/OUT** - These are a standard RJ45 CAT5 connectors (with optional NEUTRIK NE8MC RJ45 cable connector carrier), used for PRONET network transmission of remote control data over long distance or multiple unit applications.

**TERMINATE** - In a PRONET network the last loudspeaker device must be terminated (with an inner load resistance) especially in a long run cabling: press this switch if you want to terminate the unit.

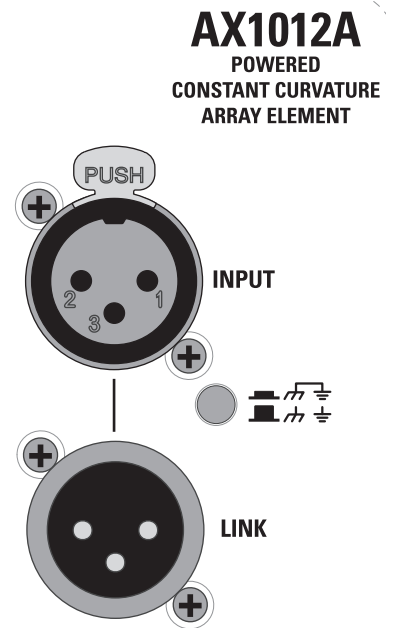



40 m LONG-THROW

25 m MID-THROW

AUDIENCE FLOOR

## POWER AMPLIFIERS

The AX1012A is powered by a DA SERIES digital power module, a new generation of CLASS D power amplifier with SMPS. The innovative technology used for these amplifiers offers top-of-the-range performances, such as a superior sound definition at any audio frequency, very high dynamics even for low level signals, and very low distortion even at maximum power. The superior sound quality can be compared with top-of-the-range AB-class analog systems, while the DA module features higher dynamic range, very compact size, light weight, and efficiency above 90%. Output power is optimised specifically to the drive units for efficient power transfer, with the low frequency section producing 900 watts while 300 watts is available for the high frequency compression driver.



**WARNING** It is strongly advisable to not install the loudspeakers with the back-plate exposed directly to sun rays for a long period of time, because this could cause the amplifier temperature protection to trip in order to safeguard the system integrity.

## SIGNAL PROCESSING

The system processing is based on the CORE DSP platform, which has been designed by the PROEL R&D Laboratories using one of the most advanced SHARC DSP for audio application. It features 40bit, 96kHz floating point resolution and high quality 24bit AD/DA converters, for a perfect signal integrity, a dynamic range in excess of 110dB and a superior sonic performance. Thanks to its massive processing power, the CORE platform is capable of providing the most sophisticated algorithms for speaker processing, together with remote control and networking capability. The PRONET AX control software, working on a solid and reliable CANBUS based network protocol, provides an intuitive interface for the remote control of the whole system, with the possibility of eqing, delaying, increasing the protections and monitoring the status of the amplifier.

## PRONET AX

PRONET AX software has been developed in collaboration with sound engineers and sound designers, in order to offer an “easy-to-use” tool to setup and manage your audio system. With PRONET AX you can visualize signal levels, monitor internal status and edit all the parameters of each connected device.

**Download the PRONET AX app from the AXIOM website at <http://www.axiomproaudio.com/> clicking on downloads section of the product.**

The AXIOM active loudspeaker devices can be connected in a network and controlled by the PRONET AX software, for the network connection the PROEL **USB2CAN** (with 1-port) or the **USB2CAN-D** (with 2-port) converter optional accessory is needed.

PRONET AX network is based on a “bus-topology” connection, where the first device is connected to the network input connector of the second device, the second device network output is connected to the network input connector of the third device, and so on. To ensure a reliable communication the first and the last device of the “bus-topology” connection must be terminated. **This can be done by pressing the “TERMINATE” switch near the network connectors in the rear panel of the first and the last device.** For the network connections simple RJ45 cat.5 or cat.6 ethernet cables can be used (please don’t confuse a ethernet network with a PRONET AX network these are completely different and must be fully separated also both use the same kind of cable).

## Assign the ID number

To work properly in a PRONET AX network each connected device must have a unique identifier number, called ID. By default the USB2CAN-D PC controller has ID=0 and there can be only one PC controller. Every other device connected must have its own unique ID equal or greater than 1: in the network cannot exist two devices with the same ID.

In order to correctly assign a new available ID to each device for working properly in a Pronet AX network, follow these instructions:

1. Switch off all the devices.
2. Connect them correctly to the network cables.
3. “TERMINATE” the end device in the network connection.
4. Switch on the first device keep pressed “PRESET” button on the control panel.
5. Leaving the previous device switched on, repeat the previous operation on the next device, until the latest device is turned on.

The “Assign ID” procedure for a device makes the internal network controller to perform two operations: reset the current ID; search the first free ID in the network, starting from ID=1. If no other devices are connected (and powered on), the controller assume ID=1, that is the first free ID, otherwise it searches the next one left free.

These operations ensure that every device has its own unique ID, if you need to add a new device to the network you simply repeat the operation of step 4. Every device maintains its ID also when it is turned-off, because the identifier is stored in the internal memory and it is cleared only by another “Assign ID” step, as explained above.

**If you use a set of loudspeakers made always of the same devices, the assign ID procedure must be performed only the first time the system is turned on.**

For more details about PRONET see the PRONET AX USER’S MANUAL included with the software.





### PREDICTION: EASE Focus 3

To aim correctly a complete system we suggest to use always the Aiming Software - EASE Focus 3:

The EASE Focus 3 Aiming Software is a 3D Acoustic Modelling Software that serves for the configuration and modelling of Line Arrays and conventional speakers close to reality. It only considers the direct field, created by the complex addition of the sound contributions of the individual loudspeakers or array components.

The design of EASE Focus is targeted at the end user. It allows the easy and quick prediction of the array performance in a given venue. The scientific base of EASE Focus stems from EASE, the professional electro- and room acoustic simulation software developed by AFMG Technologies GmbH. It is based on the EASE GLL loudspeaker data file required for its use, please note that there are multiple GLL files for the AX1012A systems. Each GLL file contains the data that defines the Line Array with regard to its possible configurations as well as to its geometrical and acoustical properties that are different from vertical or horizontal applications.

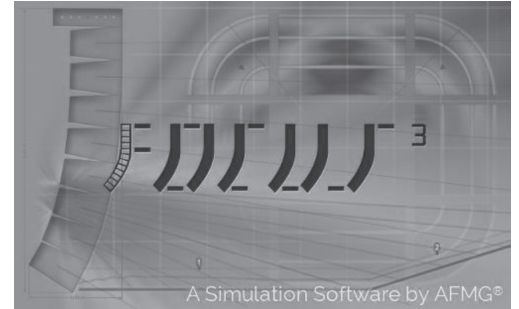

Download the EASE Focus 3 app from the AXIOM website at <http://www.axiomproaudio.com/> clicking on downloads section of the product.

Use the menu option **Edit / Import System Definition File** to import the GLL files about **AX1012A** configurations from the installation Data folder, the detailed instructions to use the program are located in the menu option **Help / User's Guide**.

*Note: Some windows system can require the .NET Framework 4 that can be download from microsoft website at <http://www.microsoft.com/en-us/download/default.aspx>.*



#### **WARNING! CAREFULLY READ THE FOLLOWING INSTRUCTIONS AND CONDITION OF USE:**

- This loudspeaker is designed exclusively for Professional audio applications. **The product must be installed by qualified personal only.**
- Proel strongly recommends that this loudspeaker cabinet be suspended taking into consideration all current National, Federal, State and Local regulations. Please contact the manufacturer for further information.
- Proel do not accept any liability for damage caused to third parties due to improper installation, lack of maintenance, tampering or improper use of this product, including disregard of acceptable and applicable safety standards.
- During assembly pay attention to the possible risk of crushing. Wear suitable protective clothing. Observe all instructions given on the rigging components and the loudspeaker cabinets. When chain hoists are in operation ensure that there is nobody directly underneath or in the vicinity of the load. Do not under any circumstances climb on the array.

### Pin locking set up

This figure shows how to insert correctly the locking pin.

## LOCKING PINS INSERTION

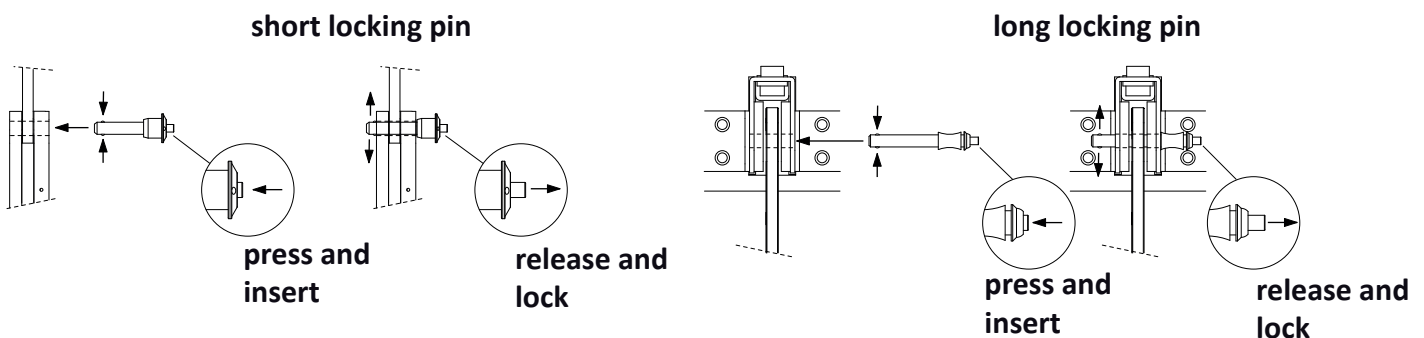



## RIGGING INSTRUCTIONS

AX1012A arrays deliver seamless coverage only to desired areas minimizing unwanted reflections of walls and surfaces or avoiding interactions with other sound systems, with the stage or with other areas. Multiple units in horizontal or vertical array allow to shape the radiation pattern in slices of 20°, providing exceptional flexibility in the construction of the desired coverage angle.

The AX1012A cabinet is provided with four integrated steel rails, to be used for coupling the cabinets with the KPTAX1012 aluminium coupling bars. A comprehensive set of accessories is available for rigging horizontal or vertical arrays, for ground-stacking the systems and also for pole mounting one or two units. The rigging system does not require additional adjustments, since the aiming angle of the array is determined only by using the proper hole in the flying bars with the use of the predicting software.

The following instructions show how to proceed to assemble the speakers in order to form various type of array, starting from a simple 2 units horizontal array to more complex ones: please read all of them carefully.

### 2-UNIT HORIZONTAL ARRAY

Follow the sequence below to couple two AX1012A units in an horizontal array: you can use the same procedure for assembling all horizontal arrays. Each AX1012A has several bumpers on each side of the box that fits in the slots of the adjacent box: this allows to arrange the boxes perfectly aligned for inserting easily the coupling and flying bars.

**1) Place the box on the floor exactly under the lifting point.**

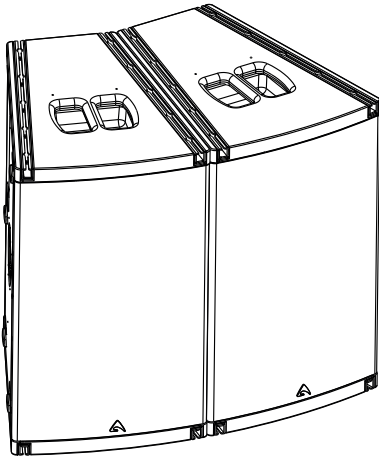

**2) Remove the locking plate at the end of the flying bar.**

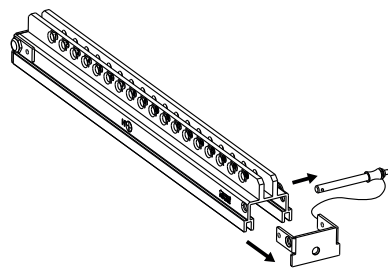

**3) Insert the bar in the rails from the front of the speakers.**

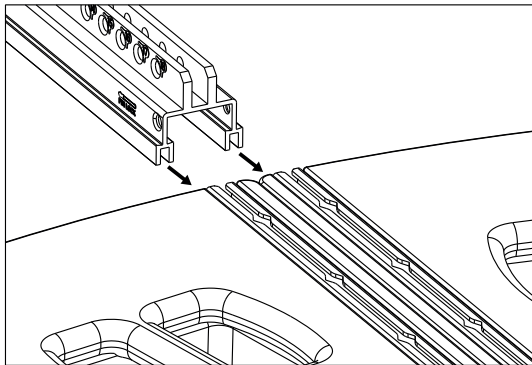

**4) Put back in place the locking plate and lock it with the pin.**

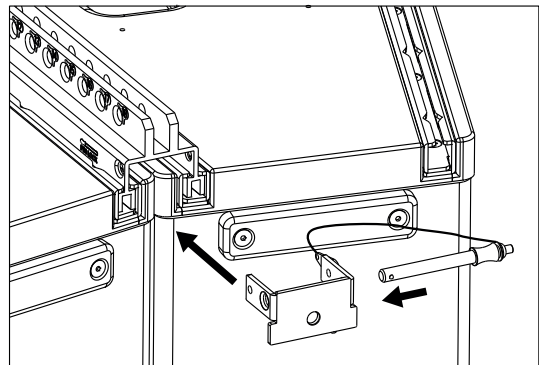

**5) Place the cam into the hole chosen for lifting: always be sure that all pins are firmly inserted in their position.**

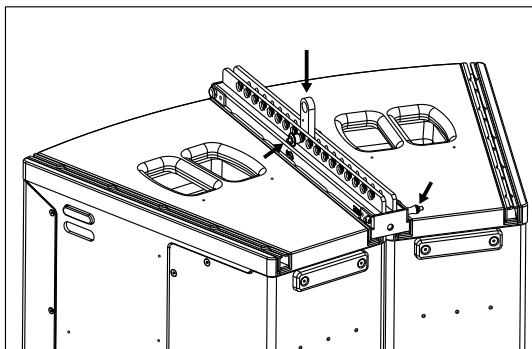

**6) Connect the lifting system using the supplied shackle.**

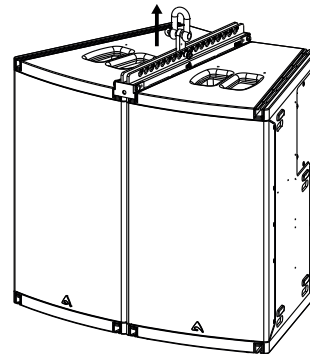



7) Lift the system to an height that allows to insert the coupling bar into the cabinet's bottom.

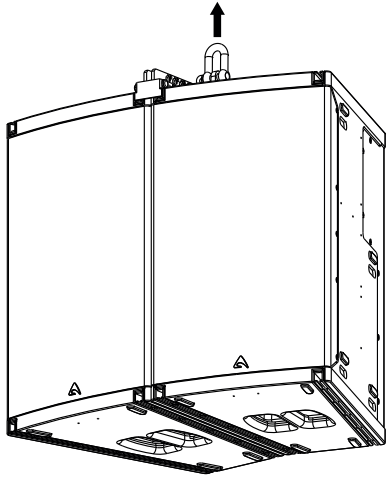

8) Remove the locking plate at the end of the coupling bar.



9) Insert the coupling bar in the rails from the front of the speakers.

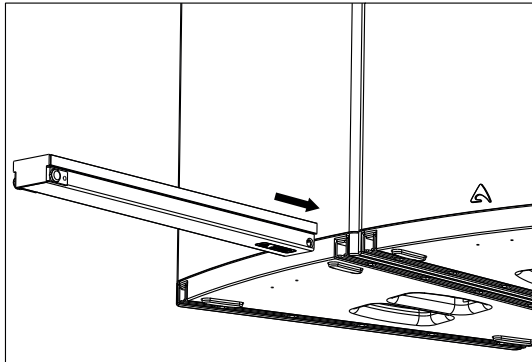

10) Put back in place the locking plate and lock it with the pin.

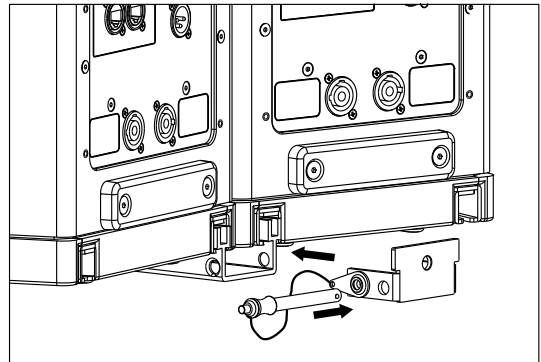

### HORIZONTAL ARRAY EXAMPLES

For more complex horizontal arrays made of from 3 to 6 units you can proceed in a similar way, assembling the whole system to the ground and raising it up all together. The following figures show how to arrange 2 to 6 units horizontal arrays.

**NOTE:** remember that one **PLG714** shackle is supplied with each **KPTAX1012H** horizontal flying bar and three **PLG714** shackles are supplied with each **KPTAX1012T** suspension bar.

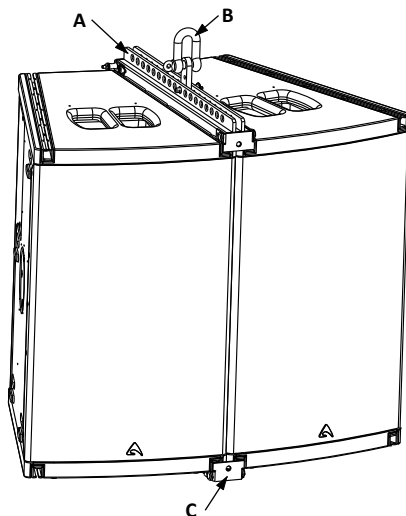

**2x AX1012A HOR. ARRAY**  
**40° x 100° coverage**  
**72 Kg total weight**

list of rigging material:

- A) 1x KPTAX1012H
- B) 1x PLG714
- C) 1x KPTAX1012





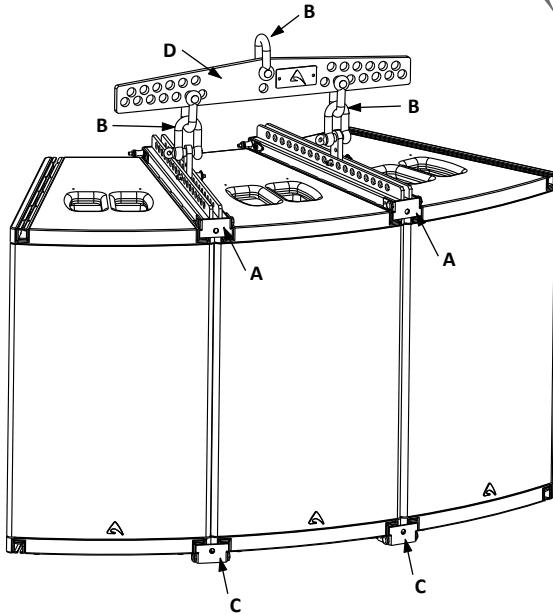

**3x AX1012A HOR. ARRAY**

**60° x 100° coverage**

**111 Kg total weight**

list of rigging material:

- A) 2x KPTAX1012H
- B) 5x PLG714
- C) 2x KPTAX1012
- D) 1x KPTAX1012T

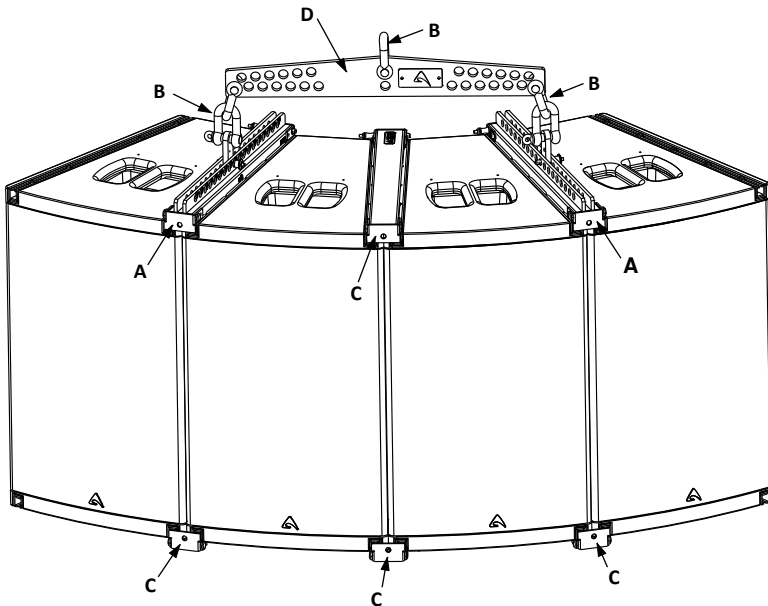

**4x AX1012A HOR. ARRAY**

**80° x 100° coverage**

**147 Kg total weight**

list of rigging material:

- A) 2x KPTAX1012H
- B) 5x PLG714
- C) 4x KPTAX1012
- D) 1x KPTAX1012T

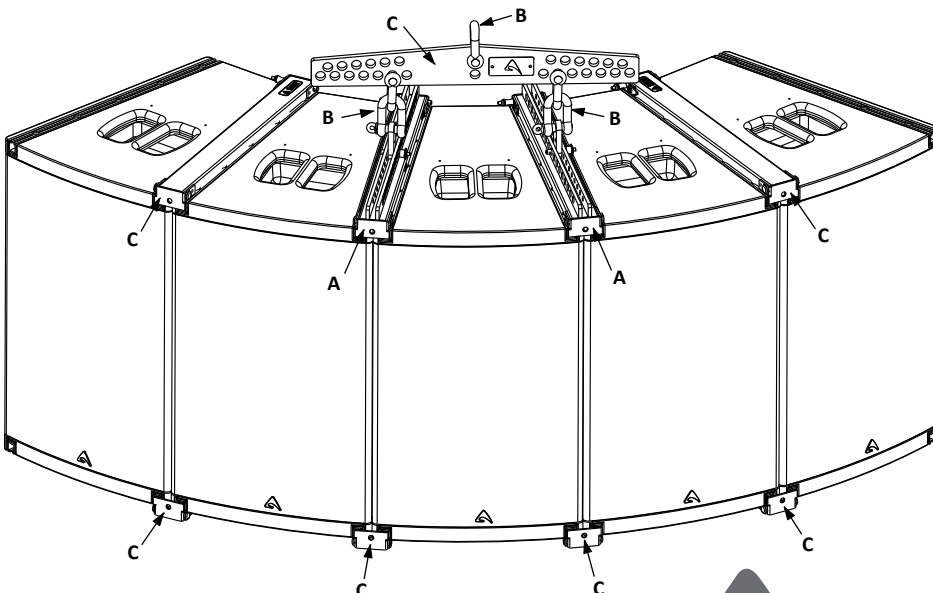

**5x AX1012A HOR. ARRAY**

**100° x 100° coverage**

**183 Kg total weight**

list of rigging material:

- A) 2x KPTAX1012H
- B) 5x PLG714
- C) 6x KPTAX1012
- D) 1x KPTAX1012T



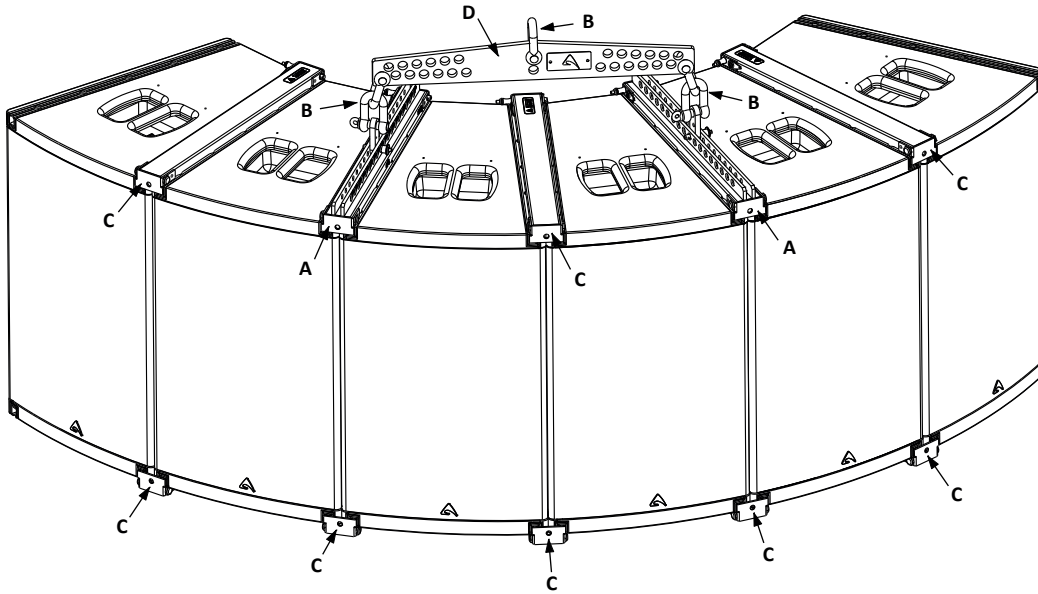

**6x AX1012A HOR. ARRAY**  
**120° x 100° coverage**  
**217 Kg total weight**  
 list of rigging material:  
 A) 2x KPTAX1012H  
 B) 5x PLG714  
 C) 8x KPTAX1012  
 D) 1x KPTAX1012T

For horizontal arrays made of more than 6 loudspeakers, as a rule of thumb **one KPTAX1012H flying bar** should be used at most **every two or three boxes**, as in the following examples. When flying arrays with more than 6 units, it is advisable to use **multiple lifting points connected directly to the KPTAX1012H flying bars**, without using the KPTAX1012T suspension bars.

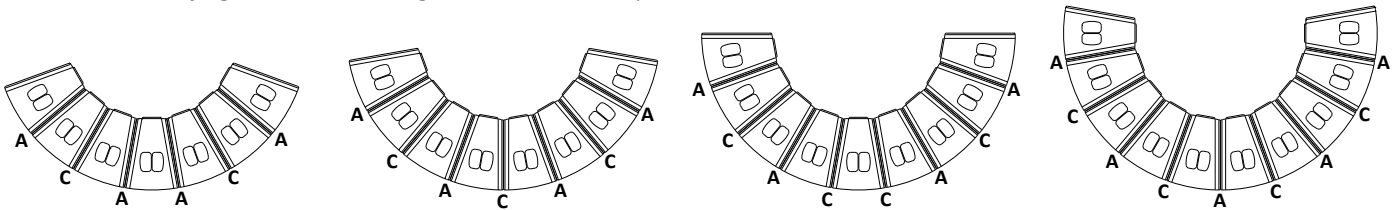

A) KPTAX1012H HORIZONTAL ARRAY FLYING BAR  
 C) KPTAX1012 COUPLING BAR

## 2-UNIT VERTICAL ARRAY

Follow the sequence below to assemble up to four AX1012A units into a vertical array. Each AX1012A has several bumpers at each side of the box that fits in the slots of the adjacent box: this allows to arrange the boxes perfectly aligned for inserting easily the coupling bars.

The first step before lifting up the system is to assemble the fly bar to the first box. Be careful to insert properly all the bars and their locking pins, with the shackle in the right hole as specified by the aiming software. When lifting and releasing the system, always proceed slowly and gradually step by step, being careful to correctly assemble all the rigging hardware and to avoid endangering yourself and your hands from being crushed.

**NOTE:** remember that one **PLG714** shackle is supplied with the **KPTAX1012V** vertical flying bar.

**1) Remove the pins at the end of the flying bar, insert the flying bar into the rails of the first box.**

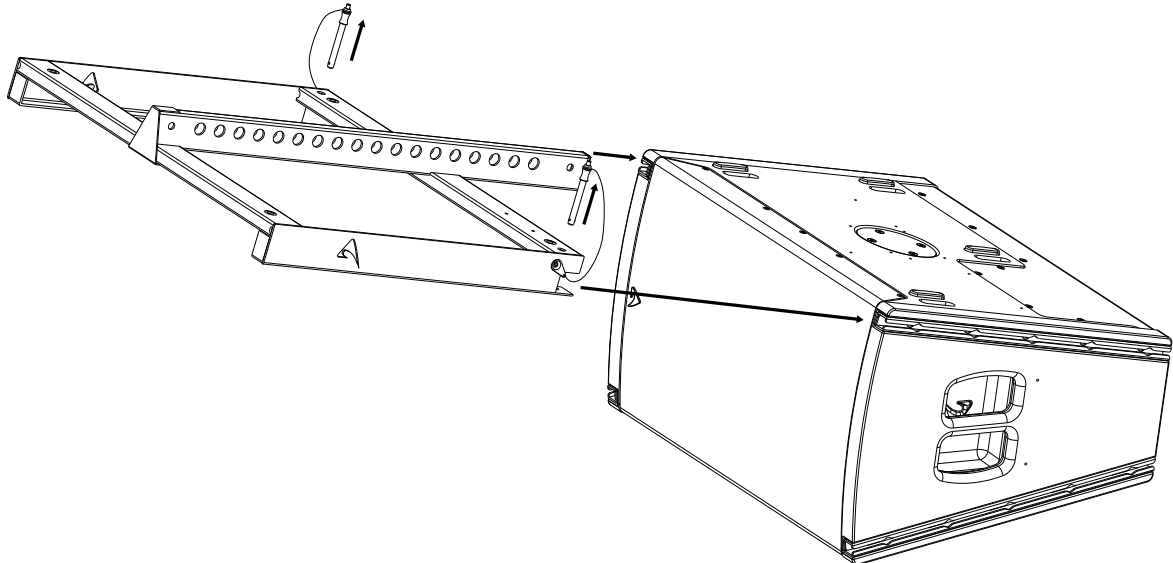



2) Put back in place the pins in their hole, making sure that they are inserted correctly. Fix the shackle in the chosen hole and link the lifting system.

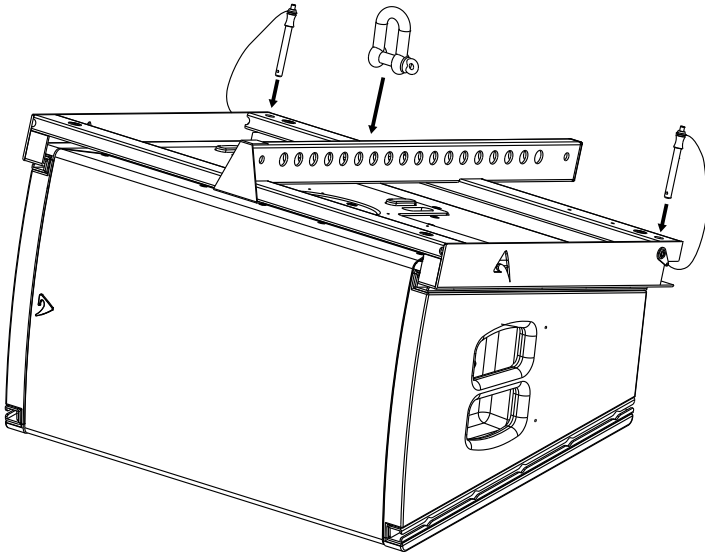

3) Lift the first box, place the second box on the floor just underneath the first one. Let down slowly the first box over the second one, aligning the bumpers and the slots of the two loudspeakers. Note: a proper wedge placed between the cabinet to be linked and the floor can be useful.

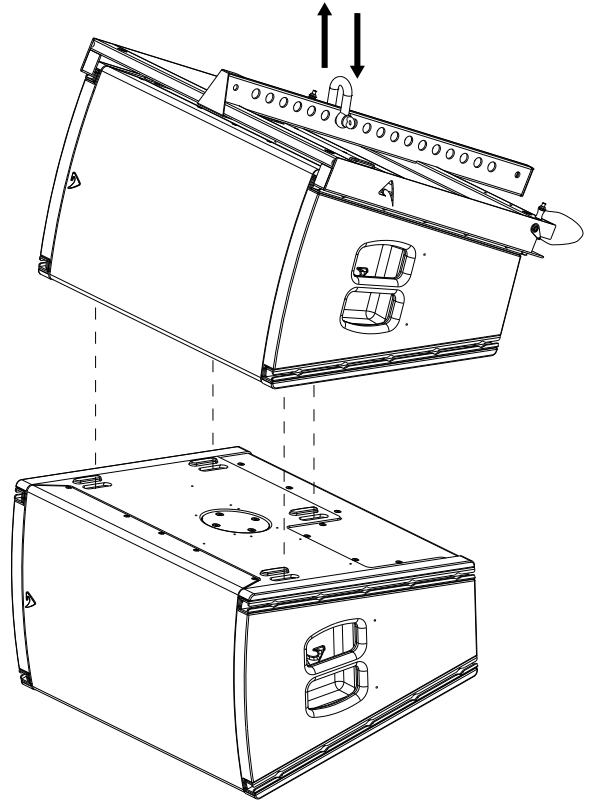

4) Link the first box to the second box using two coupling bars: remove the pins and the locking plates and insert the bars into the cabinet rails from the front.

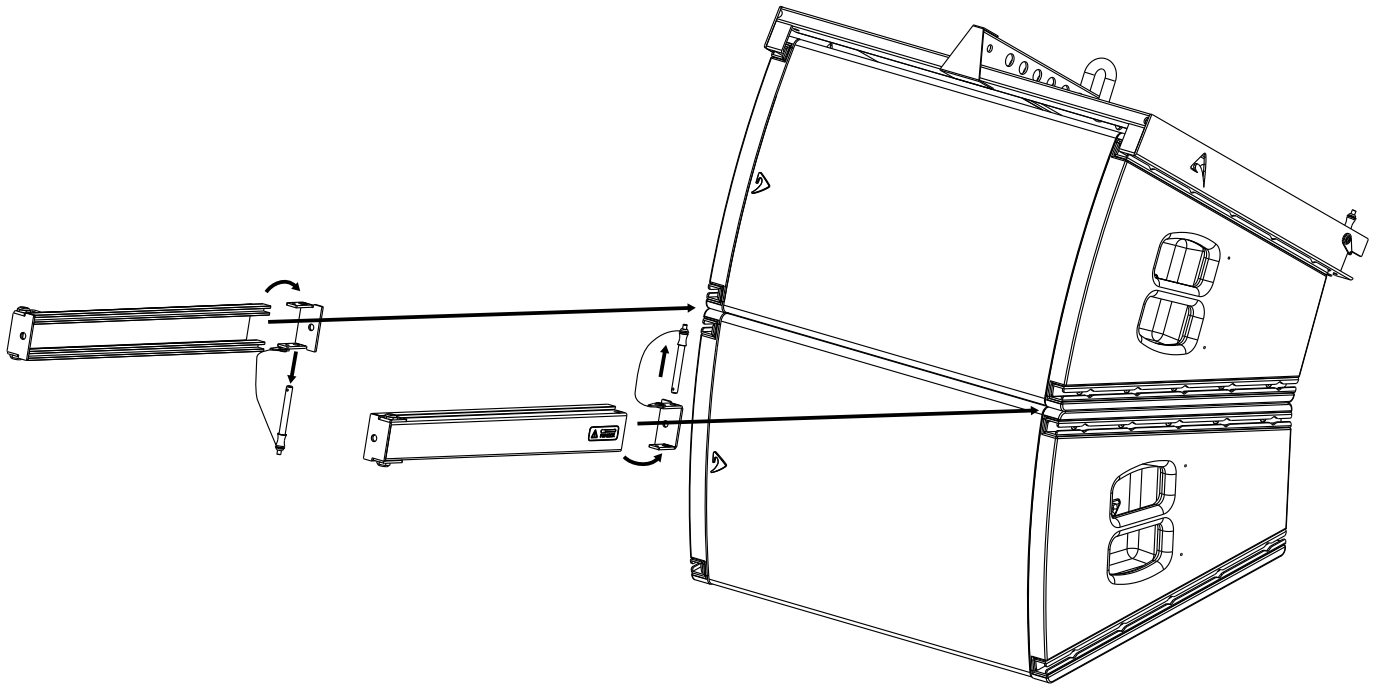



5) Put back in place the locking plates and fix them reinserting the pins in their hole.

6) Be sure that all hardware is firmly fixed before lifting the system and proceeding to link the third and fourth boxes (if required).

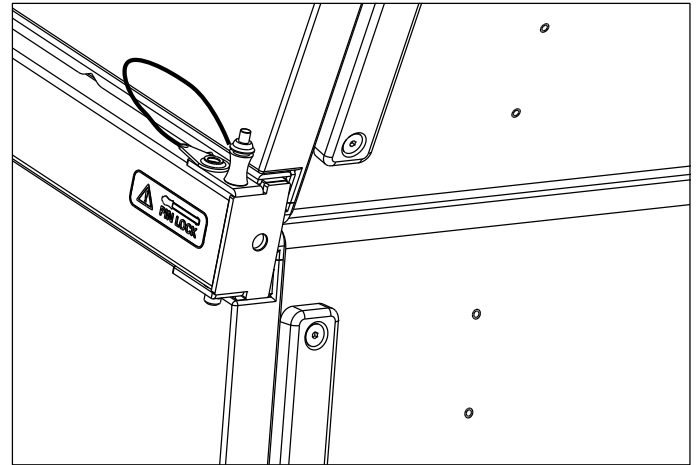
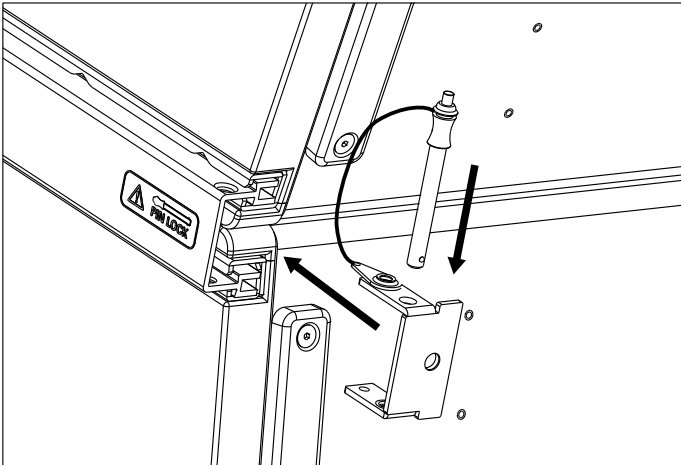

**Note:** in a vertical array, since the first unit can be connected to the flybar indifferently from either side of the box, the HF horn can result either to the left or to the right side of the array. In a small venue, could be a good choice to place the HF horns of each left and right array symmetrically to the external, to obtain a more coherent stereo image in the centre of the venue. In medium or large venues the symmetrical HF horn placement is less important due to the bigger distance between the left and right arrays.

### VERTICAL ARRAY EXAMPLES

The following figures are examples of vertical arrays made of from 2 to 4 units. **NOTE: 4 is the maximum number of units in a vertical array.**

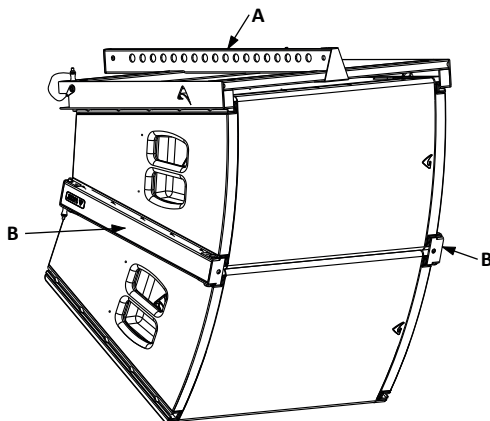

**2x AX1012A VER. ARRAY**  
**100° x 40° coverage**  
**78.5 Kg total weight**  
 list of rigging material:  
 A) 1x KPTAX1012V  
 B) 2x KPTAX1012

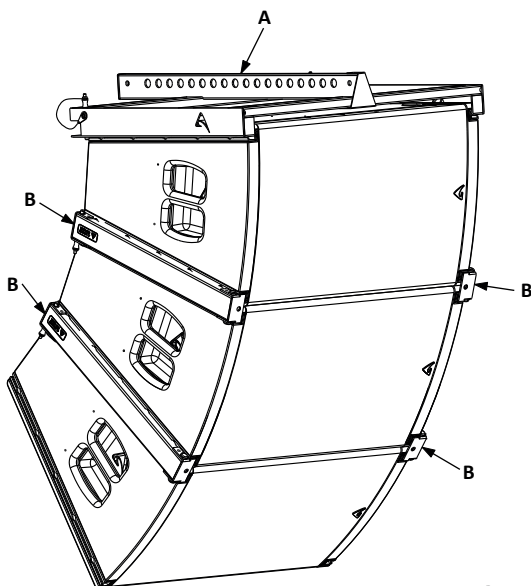

**3x AX1012A VER. ARRAY**  
**100° x 60° coverage**  
**114.5 Kg total weight**  
 list of rigging material:  
 A) 1x KPTAX1012V  
 B) 4x KPTAX1012



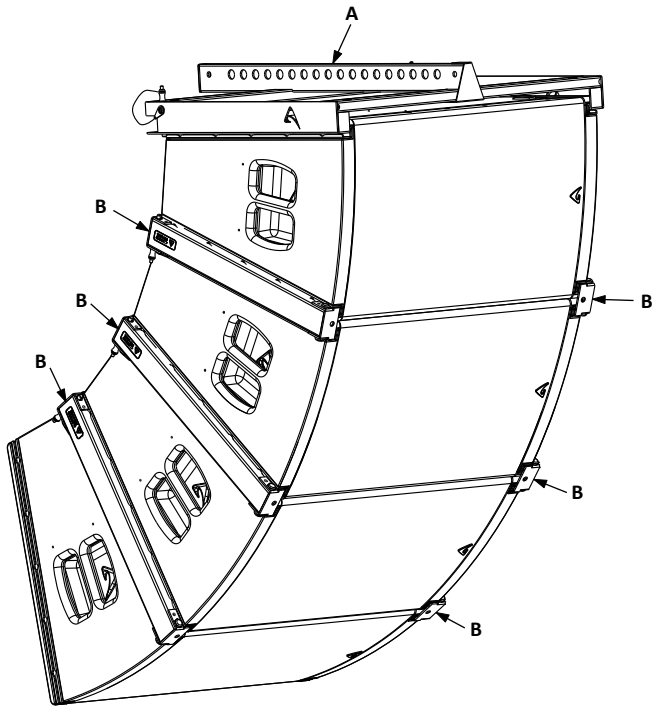

**4x AX1012A VER. ARRAY**

**100° x 80° coverage**

**150.5 Kg total weight**

list of rigging material:

A) 1x KPTAX1012V

B) 6x KPTAX1012

**DOWN-FIRING ARRAY EXAMPLE**

One additional use of AX1012A in vertical array configuration is as down-firing system, with a maximum of 4 units. In this case two KPTAX1012V flying bars are used, one at each side of the array, so the array can be suspended from two points and aimed to be completely on the vertical axis, as in the figure below:

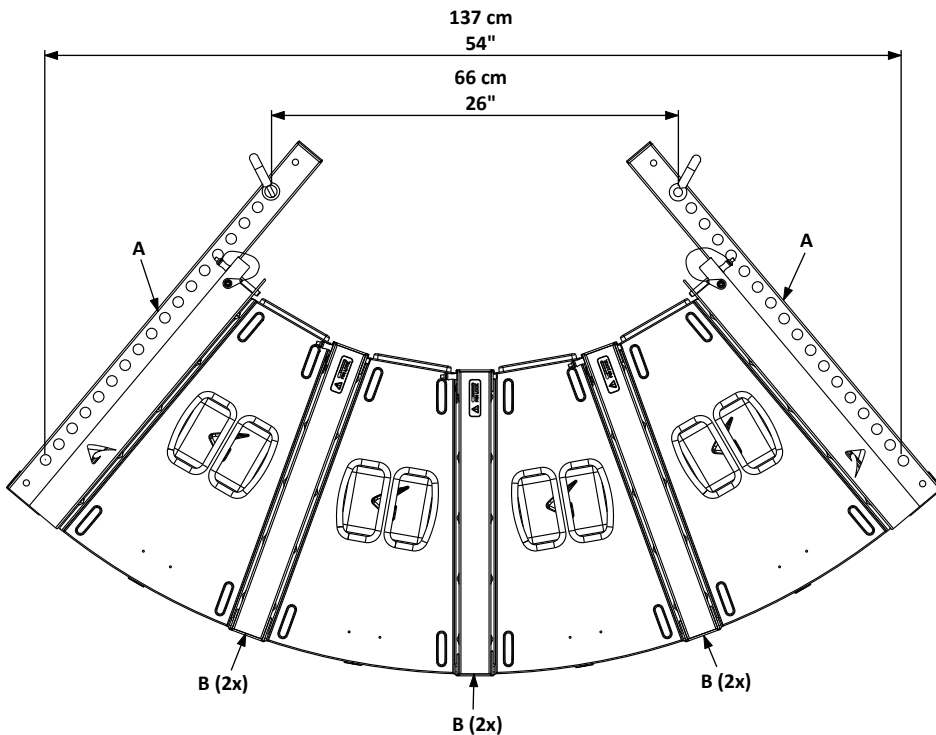

**4x AX1012A DOWN-FIRING VERTICAL ARRAY**

**100° x 80° coverage**

**158.5 Kg total weight**

list of rigging material:

A) 2x KPTAX1012V

B) 6x KPTAX1012

Any hole of both flybar can be used in the range of the two quotes specified in the drawing.





## WIND LOADS

When planning an open-air event it is essential to obtain current weather and wind information. When loudspeaker arrays are flown in an open-air environment, possible wind effects must be taken into account. Wind load produces additional dynamic forces acting on the rigging components and the suspension, which may lead to a dangerous situation. If according to the forecast wind forces higher than 5 bft (29-38 Km/h) are possible, the following actions have to be taken:

- The actual on-site wind speed has to be monitored permanently. Be aware that wind speed typically increases with height above ground.
- Suspension and securing points of the array should be designed to support double the static load in order to withstand any additional dynamic forces.



### WARNING!

Flying loudspeakers overhead at wind forces higher than 6 bft (39-49 Km/h) is not recommended. If the wind force exceeds 7 bft (50-61 Km/h) there is a risk of mechanical damage to the components which may lead to a dangerous situation for persons in the vicinity of the flown array.

- Stop the event and make sure that no person remains in the vicinity of the array.
- Lower and secure the array.

## STACKED SYSTEMS



### WARNING!

- The ground where the KPTAX1012V flying bar serving as ground support is placed must be absolutely stable and compact.
- Adjust the feet so to put the bar in a perfectly horizontal position.
- Always secure ground stacked setups against movement and possible tipping over.
- A maximum of 3 x AX1012A cabinets with the KPTAX1012V flying bar serving as ground support are allowed to be set up in a ground stack.

For the stack configuration you must use four optional BOARDACF01 feet and the fly bar must be mounted upside down to the ground.

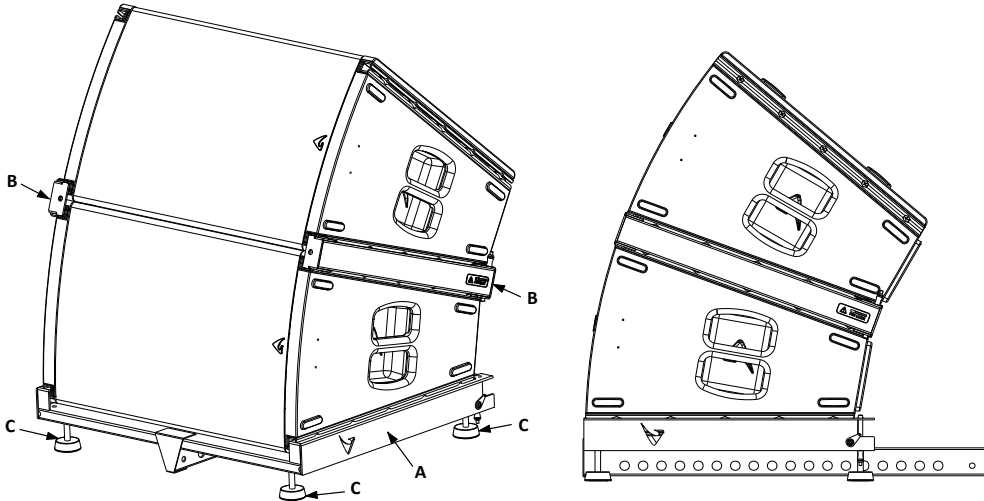

### 2x AX1012A STACKED VER. ARRAY

**100° x 40° coverage**  
**78.5 Kg total weight**

list of stacking material:

- A) 1x KPTAX1012V
- B) 2x KPTAX1012
- C) 4x BOARDACF01

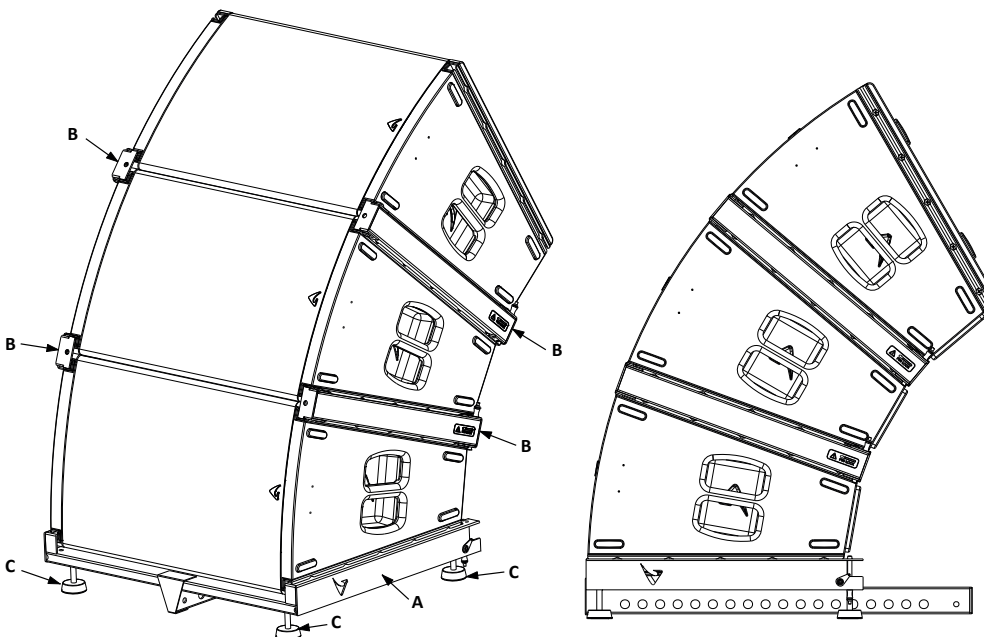

### 3x AX1012A STACKED VER. ARRAY

**100° x 60° coverage**  
**114.5 Kg total weight**

list of stacking material:

- A) 1x KPTAX1012V
- B) 4x KPTAX1012
- C) 4x BOARDACF01



## POLE MOUNTING

One single AX1012A loudspeaker can be also installed on a pole and used standalone or in combination with a sub woofer (suggested model is SW1800A).

To install the AX1012A on a pole, the round plate on the left side of the loudspeaker must be replaced with the KPAX265 pole adapter (use a 4mm hex key or screwdriver) and the KP010 tilt adapter must be used as a link to the pole. If the AX1012A is installed on a subwoofer, we suggest to use the DHSS10M20 pole to adjust the height. Set the tilt angle to  $-10^{\circ}$  to aim the loudspeaker parallel to floor (see figures below).

**1) Remove the round plate.**

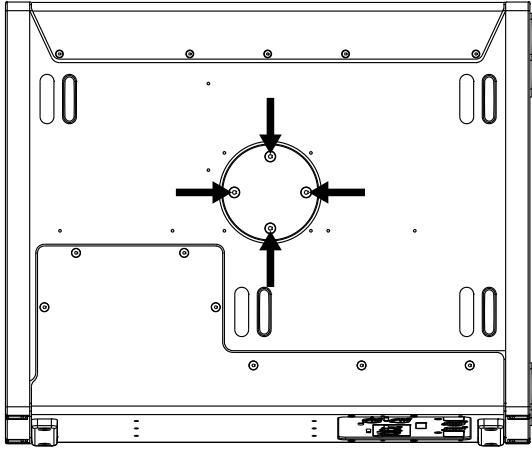

**2) Mount the KPAX265 pole adapter.**

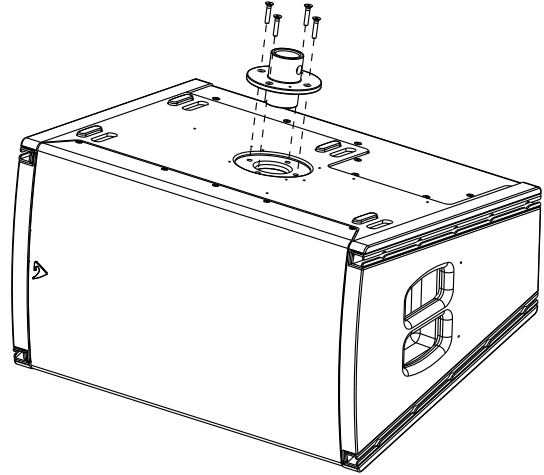

**3) Insert the KP010 tilt adapter into the KPAX265 and install the AX1012A to the pole. Aim the tilt adapter  $10^{\circ}$  down to align the AX1012A to the floor and fix its pin. Adjust the pole's height if needed.**

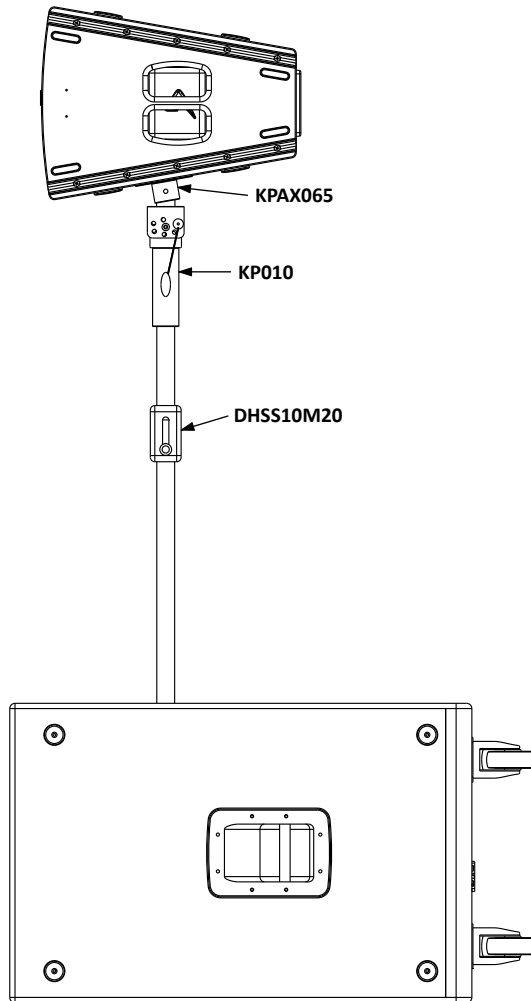



### LIMITED WARRANTY

Proel warrants all materials, workmanship and proper operation of this product for a period of two years from the original date of purchase. If any defects are found in the materials or workmanship or if the product fails to function properly during the applicable warranty period, the owner should inform about these defects the dealer or the distributor, providing receipt or invoice of date of purchase and defect detailed description. This warranty does not extend to damage resulting from improper installation, misuse, neglect or abuse. Proel S.p.A. will verify damage on returned units, and when the unit has been properly used and warranty is still valid, then the unit will be replaced or repaired. Proel S.p.A. is not responsible for any "direct damage" or "indirect damage" caused by product defectiveness.

- This unit package has been submitted to ISTA 1A integrity tests. We suggest you control the unit conditions immediately after unpacking it.
- If any damage is found, immediately advise the dealer. Keep all unit packaging parts to allow inspection.
- Proel is not responsible for any damage that occurs during shipment.
- Products are sold "delivered ex warehouse" and shipment is at charge and risk of the buyer.
- Possible damages to unit should be immediately notified to forwarder. Each complaint for package tampered with should be done within eight days from product receipt.

### SAFETY INSTRUCTIONS

- To reduce the risk, close supervision is necessary when the product is used near children.
- Protect the apparatus from atmospheric agents and keep it away from water, rain and high humidity places.
- This product should be site away from heat sources such as radiators, lamps and any other device that generate heat.
- This product should be located so that its location or position does not interfere with its proper ventilation and heating dissipation.
- Care should be taken so that objects and liquids do not go inside the product.
- The product should be connected to a power supply mains line only of the type described on the operating instructions or as marked on the product. Connect the apparatus to a power supply using only power cord included making always sure it is in good conditions.
- WARNING: The mains plug is used as disconnect device, the disconnect device shall remain readily operable.
- Do not cancel the safety feature assured by means of a polarized line plug (one blade wider than the other) or with a earth connection.
- Make sure that power supply mains line has a proper earth connection.
- Power supply cord should be unplugged from the outlet during strong thunderstorm or when left unused for a long period of time.

### CE CONFORMITY

Proel products comply with directive EMC 2014/30/CE, as stated in EN 55103-1 and EN 55103-2 standards and with directive LVD 2014/35/CE, as stated in EN 60065 standard.

**PROEL S.p.A. (World Headquarters) - Via alla Ruenia 37/43 - 64027 Sant'Omero (Te) - ITALY**  
Tel: +39 0861 81241 Fax: +39 0861 887862 [www.axiomproaudio.com](http://www.axiomproaudio.com)

