



KEY FEATURES

- High-Output Coaxial Stage Monitor
- Very compact size & low-profile design
- Single magnet neodymium motor
- 80° constant coverage
- Front tuning ports
- 40bit floating point CORE2 processing with PRONET AX remote control
- Digitally controlled Class D amplifier module with SMPS and PFC

APPLICATIONS

The CX15AV2 is a coaxial stage monitor designed specifically for live sound, even if the very compact, low-profile enclosure makes it suitable also for theater and television applications. The combination of a high-performance coaxial transducer, a carefully designed cabinet and powerful electronics provides a very high SPL before feedback and a great intelligibility even at very high power.

CX15AV2 represents the evolution of CX15A, with which it maintains full electroacoustic and mechanical compatibility.

TECHNICAL SPECIFICATIONS

SYSTEM

System Type	2-way processed coaxial active enclosure
Frequency Response ($\pm 3\text{dB}$)	60 Hz – 18kHz (Processed)
Horizontal / Vertical Coverage	80° (-6dB) / 80° (-6dB)
Angle	
Maximum Peak SPL @ 1m	131dB

TRANSDUCERS

LF	One 15" (380mm), 3" (75mm) Interleaved Voice Coil, 8 Ohm
HF	One 1.4" driver, 2.4" (60mm) edgewound aluminium voice coil, titanium diaphragm, 8 Ohm

ELECTRICAL

Input Impedance	20 k Ω balanced, 10 k Ω unbalanced
Input Sensitivity	+4dBu / 1.25 V
Signal Processing	CORE2 processing, 40bit floating point SHARC DSP, 24 bit AD/DA converters
Direct access Controls	4 Presets (Normal Wedge/Coupled Unit/Low Cut, User), Network Termination, GND Link
Remote Controls	PRONET AX control software
Network protocol	CANBUS
Amplifier Type	Class D with SMPS and PFC
Output Power	1400W + 1400W
Mains Voltage Range (Vac)	100 - 240 V ~ $\pm 10\%$ 50/60 Hz
IN / OUT Connectors	Neutrik XLR-M / XLR-F
IN / OUT Network Connectors	ETHERCON® (NE8FAV)
Mains Connector	PowerCon® (NAC3MPA)
Mains Link Connector	PowerCon® (NAC3MPB)
Cooling	Variable speed DC fan

ENCLOSURE & CONSTRUCTION

Physical Dimensions	
W x H x D	520 mm (20.47") x 336 mm (13.22") x 415 mm (16.33")
Monitor Taper	45° or 55°
Enclosure Material	15mm, reinforced Phenolic Birch
Paint	High resistance, water based paint
Pole holder	1 x side, dual-angle
Net Weight	18.5 Kg (40.78 lbs.)

TRANSDUCERS

The transducer's coaxial design offers a very stable acoustical pattern both on the horizontal and vertical axis. The very compact, single magnet neodymium motor reduces the delay between the two sources, eliminating time/phase problems, as well as guarantees a high performance with a consistent weight reduction.

The high frequency range is reproduced by a low-distortion compression driver, equipped with pure titanium diaphragm. An edge-wound aluminum ribbon voice coil and a copper sleeve reduce distortion and increase the unit's output. The special shape of the cone allows a precise and controlled conical dispersion of 80°.

The 15" woofer employed in the reproduction of the low frequency range is equipped with a special interleaved sandwich 3" voice coil and an aluminum demodulation ring for minimum distortion.

Thanks to special magnet plate and cone treatment process, which increase the resistance against corrosion and make the cone water repellent, the CX15AV2 is able to perform in adverse weather conditions and it is suitable for the use in outdoor events.

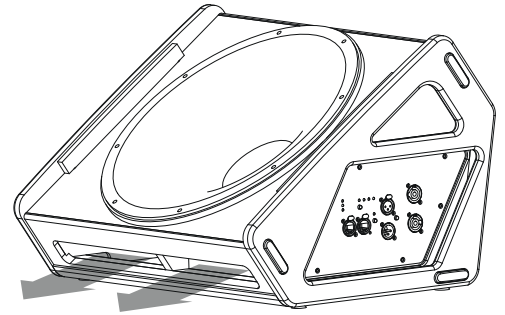

CABINET DESIGN

The reduced size of the baltic birch cabinet (only 34cm high and 55cm wide) makes the CX15AV2 one of the most compact and lightweight stage monitors in its category and makes it suitable for all applications when the unobtrusive size is a must. This includes not only live concerts, but also theater shows and TV applications.

The reduced weight (less than 19kg) and the ergonomic handles on both sides of the cabinet make very easy to transport the monitor and to position it on the stage. A convenient dual-angle pole holder allows the CX15AV2 to be placed also on a standard speaker stand.

The specially designed tuning ports, instead of being placed on the top baffle and directed towards the musician (as in a conventional stage monitor), are located on the front of the cabinet and pointed to the floor. This greatly reduces the interferences of the LF tuning with the MF range, resulting in a much more clean and well-defined sound, and also enhances the LF response in coupling with the floor. The tuning port's design also provides an efficient cooling for the amplifier.

The possibility to position the cabinet with two different angles to the floor (45° and 55°) allows to place it at different distances from the musicians, according to the size of the stage and to the kind of monitoring needed.

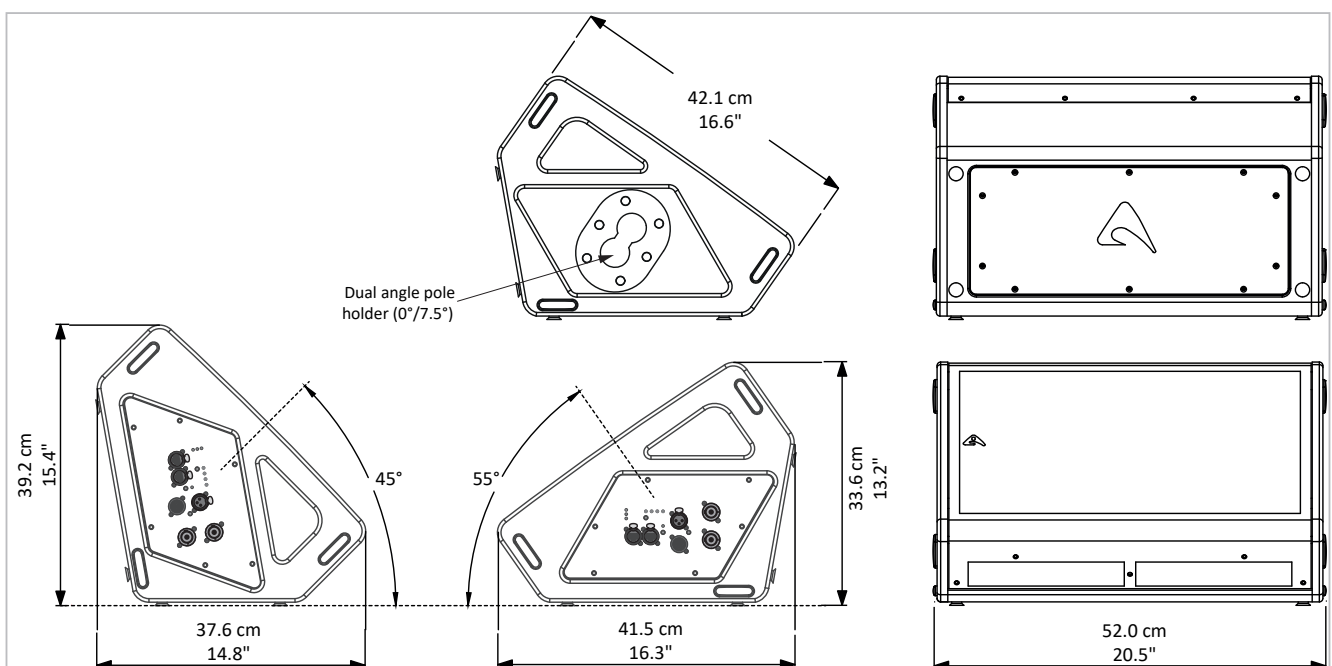

SIGNAL PROCESSING

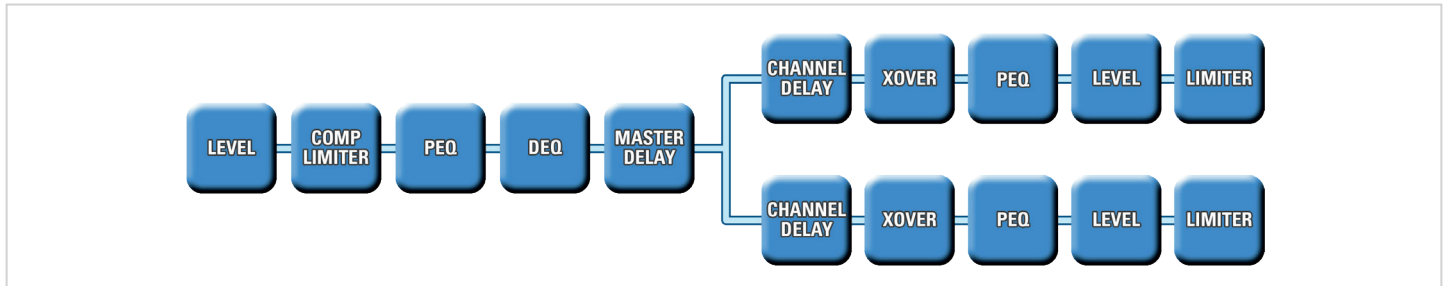

The system processing is based on the CORE2 DSP platform designed by the PROEL R&D Laboratories using one of the most advanced SHARC DSP for audio application. It features 40bit floating point resolution and top-quality 24bit AD/DA converters, for a perfect signal integrity, a dynamic range in excess of 110dB and a superior sonic performance. Thanks to its massive processing power, the CORE 2 platform is capable of providing the most sophisticated algorithms for speaker processing, together with remote control and networking capability.



The CORE2 DSP made possible to set an optimal TIME ALIGNMENT for the crossover filter resulting in a linear phase response. The correct acoustic filtering has been achieved using the Constant Power Crossover technique that, thanks to a particular phase relation, allows to obtain a very smooth transition between LF and HF and an even dispersion in the crossover region.

The PRONET AX control software, working on a solid and reliable CANBUS based network protocol, provides an intuitive interface for the remote control of the whole system, with the possibility of eqing, delaying, increasing the protections and monitoring the status of the amplifier.

POWER AMPLIFIERS

The CX15AV2 is powered by a new generation of CLASS D power amplifiers with digitally-controlled SMPS and latest generation single-stage PFC. The innovative technology used for these amplifiers offers performances at the top of the range, such as a superior sound definition at any audio frequency, very high dynamics also for low level signals and very low distortion even at the maximum power. The superior sound quality can be compared with top-of-the-range AB-class analog systems, while the CX15AV2 power modules feature a higher dynamics, very compact size and light weight and efficiency above 90%.

The power module employed for powering the CX15AV2 delivers in an ultra-compact package a total power of 2800W, 1400W for both LF woofer and HF driver. Such a large reserve of power available also for the HF driver means that the amplifier can handle very high voltage peaks, resulting in an impressive dynamic performance of the HF section.

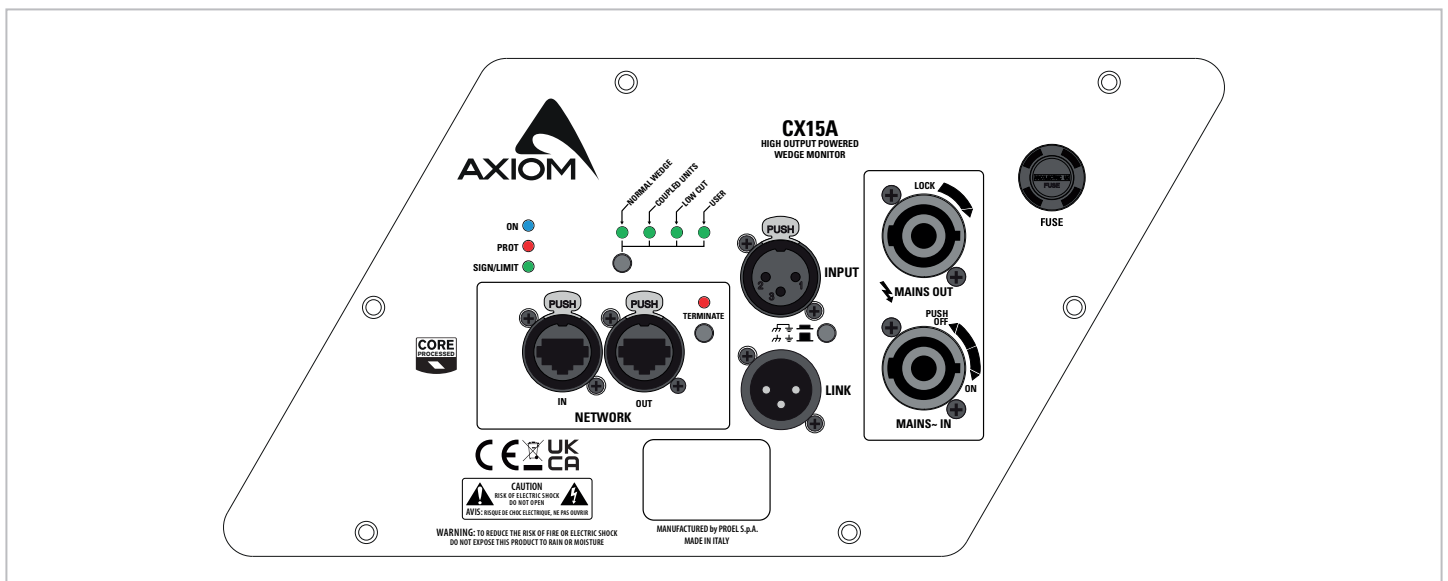

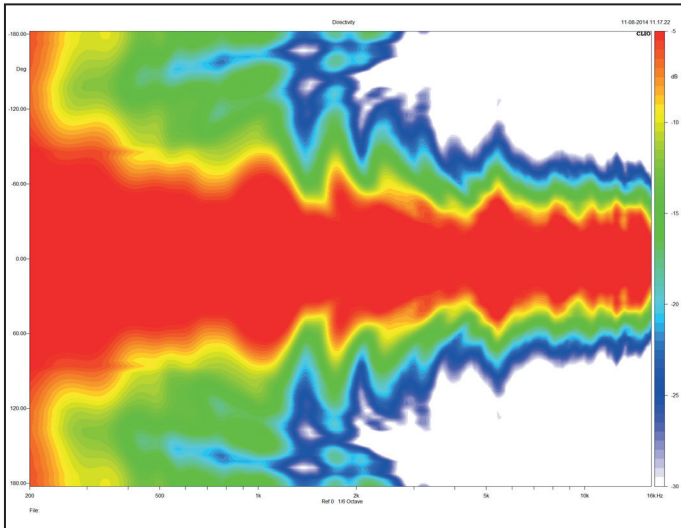

CX15AV2 directivity map

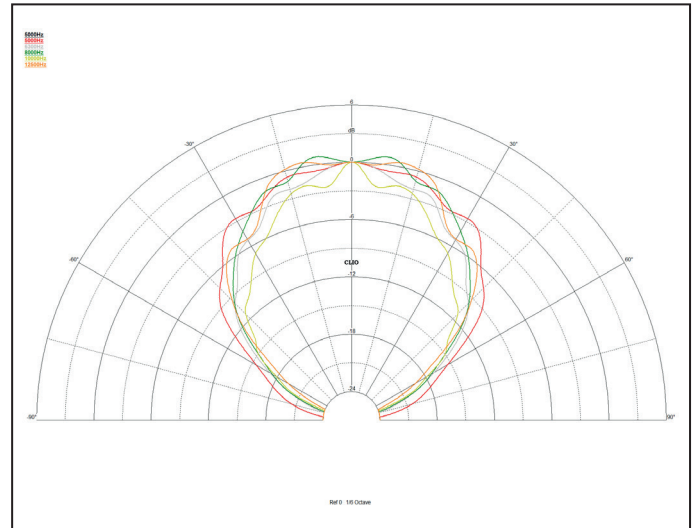

CX15AV2 angular coverage 5KHz - 12.5KHz

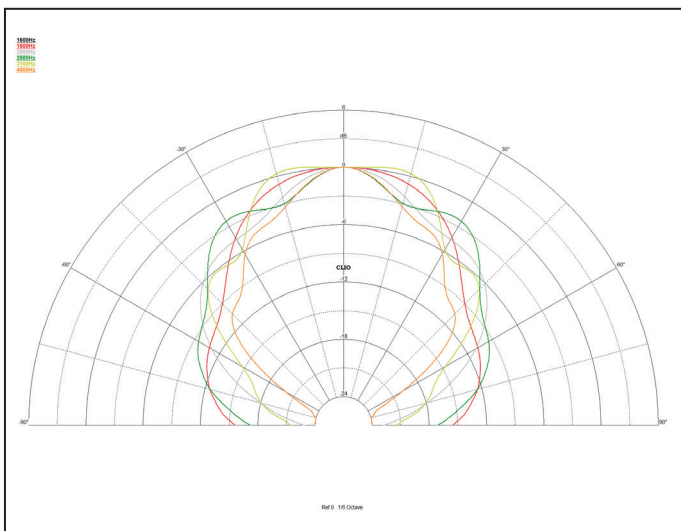

CX15AV2 angular coverage 1.6KHz - 4KHz

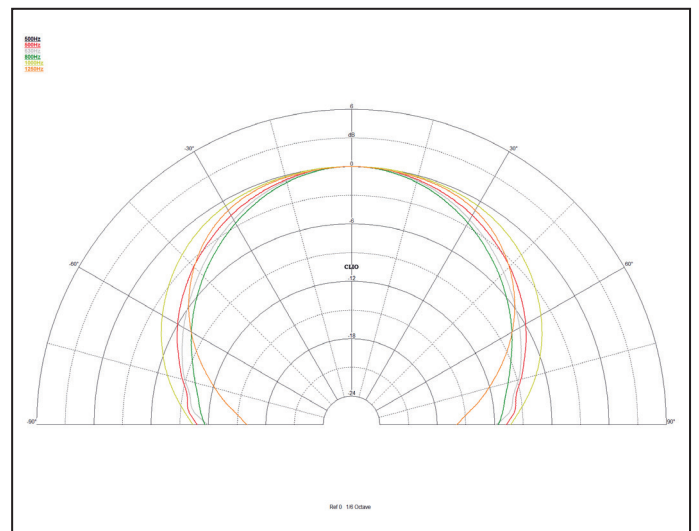

CX15AV2 angular coverage 500Hz - 1.25 KHz