

# USB3.0 HD Video Camera User Manual

Model:Angekis U3-5FHD6

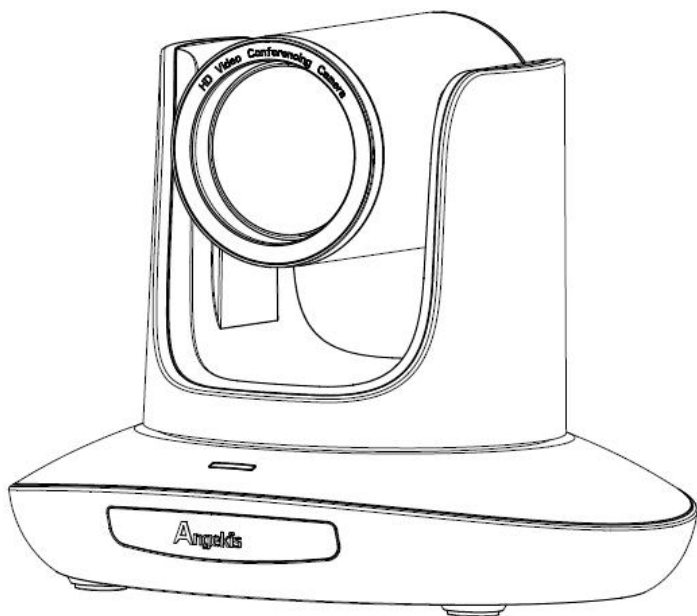

# CONTENTS

---

SAFE GUIDES .....	3
ACCESSORIES .....	5
QUICK START .....	5
PRODUCT HIGHLIGHTS .....	6
PRODUCT SPEC .....	7
CAMERA INTERFACE .....	8
CAMERA DIMENSION .....	8
IR REMOTECONTROLLER .....	9
VISCA IN(RS232) PORT .....	11
VISCA PROTPCOL .....	12
PELCO-D PROTOCOL .....	19
PELCO-P PROTOCOL .....	20
OSD MENU .....	21
IR TRANSFER(IR PASS) & UVC CONTROL .....	24

# SAFETY GUIDES

---

1. Before operation, please fully read and follow all instructions in the manual. For your safety, always keep this manual with the camera.
2. The camera power input range is 100-240VAC(50-60Hz), ensure the power supply input within this rate.
3. The camera can be powered via the factory supplied USB3.0 cable(3meters); We suggest you connect to the power adapter(supplied by the factory) if the camera is connecting to USB2.0 port or USB3.0 extender cable.
4. Please keep the power cable, video cable and control cable in a safe place. Protect all cables especially the connectors.
5. Operational environment: 0°C–50°C, humidity less than 90%. To avoid any danger, do not put anything inside the camera, and keep away from the corrosive liquid.
6. Avoid stress, vibration and damp during transportation, storage and installation.
7. Do not detach the camera housing and cover. For any service, please contact authorized technicians.
8. RF cable and control cable should be individually shielded, and cannot be substituted with other cables. Do not direct the camera lens towards strong light, such as the sun or the intensive light.
9. Use a dry and soft cloth to clean the camera housing. Applied with neutral cleaning agent when there is need to clean. To avoid damage on the camera lens, never use strong or abrasive cleaning agents on the camera housing.
10. Do not move the camera by holding the camera head. To avoid mechanical trouble, do not rotate the camera head by hand.
11. Put the camera on fixed and smooth desk or platform, avoid leaned installation.
12. Power Supply Polarity(Drawing)

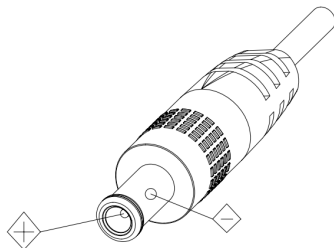

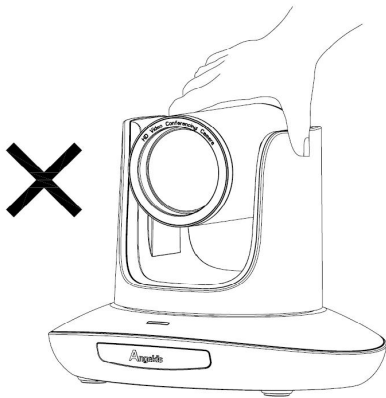

 DO NOT use hands for catching or moving the camera barrel , otherwise it may damage the camera mechanical structure.



 DO NOT use hands to quick rotate the camera barrel , otherwise it may damage the camera mechanical structure, even break the motor driving.

## ACCESSORIES

Check all bellow items when open the package:

Camera .....	1
Power Adapter .....	1
Power Cable .....	1
RS232 Control Cable .....	1
USB3.0 Cable .....	1
Remote Controller .....	1
User Manual .....	1
Double-sided Adhesive .....	1
Quality Certificate .....	1

## QUICK START

1.Check all cable connections before power on.

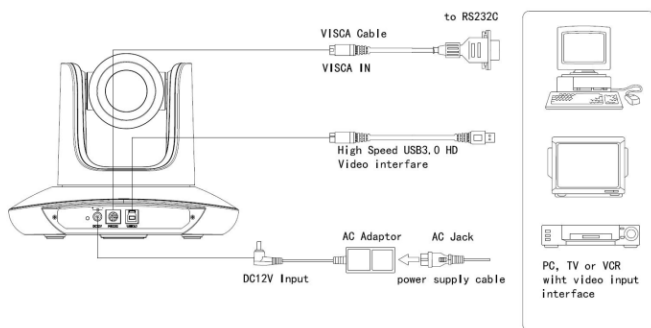

2.DIP Switch Setting (at the bottom of the camera):

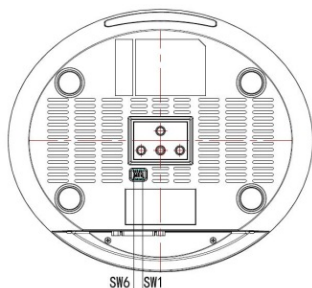

Function ( ARM )			
	SW-1	SW-2	Instruction
1	OFF	OFF	Updating mode
2	ON	OFF	Debugging mode
3	ON	ON	Working mode

Function ( USB )			
	SW-5	SW-6	Instruction
1	OFF	OFF	Working mode
2	ON	OFF	Updating mode
3	OFF	ON	Undefined
4	ON	ON	Undefined

## PRODUCT HIGHLIGHTS

- **3 cables in 1 design: video, control & power can be transited via single USB3.0 cable.**  
(notice: to achieve stable power supply via USB3.0 cable, we suggest only use the 3m USB3.0 cable supplied by the factory, and the PC's USB3.0 port can supply more than 5V 1000mA power; we suggest you connect to the power adapter(supplied by the factory) if the camera is connecting to a USB2.0 port or USB3.0 extender cable.)
- Smart and fashion design, ideal for cloud-based conferencing
- Adopts advanced DSP, 1/2.8 inch 5MP image sensor, and high quality 5X 90 degree FOV optical lens, provides fluent and crystal image quality
- Fast switching between different video formats: less than 1 second
- 5X Optical Zoom + 2X Digital Zoom
- Fast and accurate focus performance
- Easy firmware upgrade-(field-upgradable)
- USB3.0 super speed output, USB2.0 compatible
- Effective RS232/485 serial control
- Up to 128 presets
- Compatible with the majority of videoconferencing software (UVC protocol standard)
- With powerful functional remote controller
- IR transfer/IR pass function: except receiving the camera remote controller signal, the camera can also receive other codes' IR remote control signal, and pass these IR control signal to the codec's IR receiver (via VISCA IN port).
- Multi-language OSD menu: English, Chinese.

## PRODUCT SPEC

Video Format (YUY2)	USB3.0	1080P60/50/30/25, 720P60/50/30/25, 1024x576@30, 960x540@30, 640x360@30, 352x288@30
	USB2.0	1024x576@30, 960x540@30, 640x360@30, 352x288@30
Video Port	USB3.0 , USB2.0	
Sensor	1/2.8 inch high quality 5MP CMOS sensor	
Lens	F3.1~15.5mm(5X) , F1.8 ~2.8, Field of viewing: 90°(wide)-20°(tele)	
Pan/tilt Rotation	Pan:±170°; Tilt: -30°~+90°, support up-side down installation	
Pan/tilt Speed	Pan: 0.1°-120°/s; Tilt: 0.1°-80°/s	
Preset	10 via IR remote setting, 128 via VISCA control, preset accuracy :0.2°	
Control Port	RS232 /RS485 , USB3.0 /USB2.0	
Min. Lux	0.01 Lux	
White Balance	Auto/Manual/AutoTracking/OnePush/Indoor/Outdoor/Sodium Lamp/Fluorescent Lamp	
Focus	Auto/Manual	
Iris	Auto/Manual	
Shutter	Auto/Manual	
WDR	Supported	
BLC	Supported	
2D Noise Reduction	Supported	
3D Noise Reduction	Supported	
Gamma Setting	Supported	
Mirror Image	Supported	
Anti Flicker	OFF/ 50Hz/60Hz	
Input Voltage	5V 1000Ma (USB3.0) / 12V DC 1A (Power adapter)	
Dimension	220mm ×190mm ×173mm	
Net weight	1.25KG (2.8LBS)	

## CAMERA INTERFACE

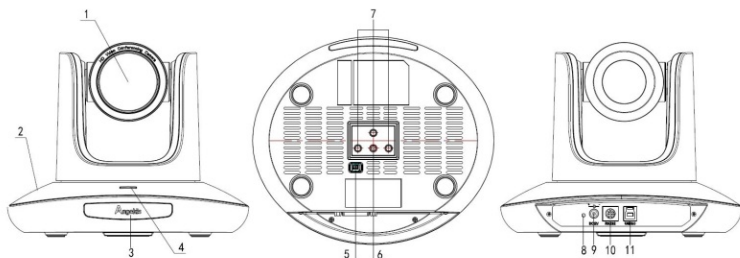

- 1.Camera Lens
- 2.Camera Base
- 3.IR Receiver Panel
- 4.Indicator Light

- 5.Dial Switch
6. Tripod Screw Hole
- 7.Installation Hole
8. Power Indicator light ( red )

9. 12VDC Power Input
- 10.RS232(VISCA IN) Port
11. USB3.0 Port

## CAMERA DIMENSION(MM)

Technical Data:  
 Max. rotation angle:  $\pm 120^\circ$   $\text{---} 120^\circ$   
 Tilt rotation angle:  $\pm 25^\circ$   $\text{---} 90^\circ$   
 Max. speed rotate: 1/1  
 Tilt speed rotate: 6.8/1

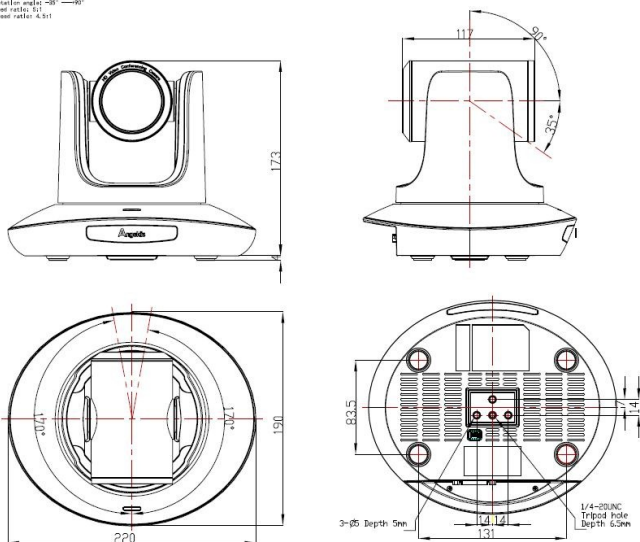



# IR REMOTE CONTROLLER

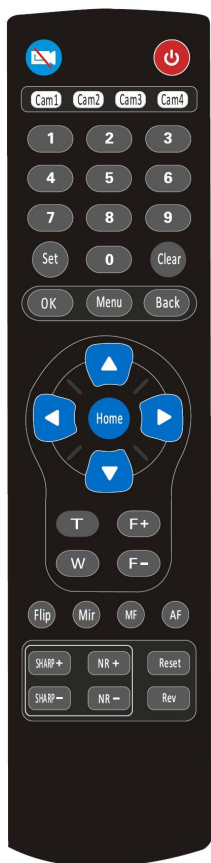

## Mute Key

Short press to close the video display and show Mute picture.

## Power Key

Under normal working mode, short press Power key to let the camera enter standby mode; Press it again, the camera will do self-configuration and then go back to HOME position; It will go to preset position if the power on mode has been set.



## Address/Camera Setting Key

Set+(Cam1~Cam4) : set camera's remotecontrol address.

Short press Cam1~Cam4 to select the camera.



## Number Key

Set Preset: Set+ (0-9) to set preset

Run Preset: short press the (0-9) number key to run preset.

## Clear Key

Clear+(0-9): to clear the relative preset

Long press to clear all preset.

## Menu Key

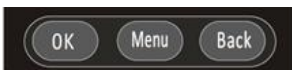

**OK** : to confirm the menu selection;

**Menu**: enter/exit menu;

**Back** : back to previous menu;

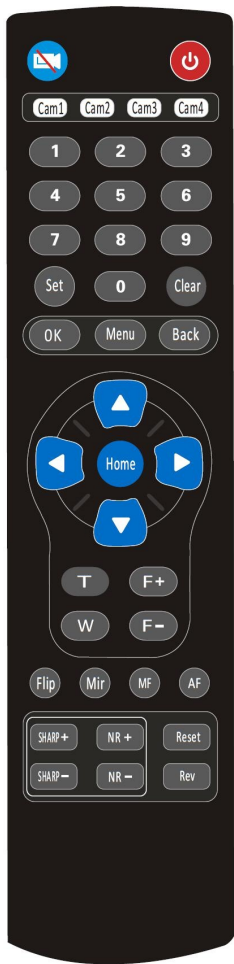

**F+/F- :**

Set focus by manual, only valid under manual focus mode.

**T/W :**

Set the lens zoom rate.

**Navigate Key : Up/Down/Left/Right**

Under normal working mode, use navigate key to set the pan tilt, and select values when enter OSD.

**Home Key :**

Under normal working mode, short press Home key to let the camera go back to home position.



**Flip :** Enable/Disable the picture up/down flip;

**Mir :** Enable/Disable the picture left/right flip;

**MF :** Enable manual focus model;

**AF :** Enable manual focus model.



**SHARP+/- :** Set sharpness level;

**NR+/- :** Set noise reduction level;

## VISCA IN (RS232) PORT

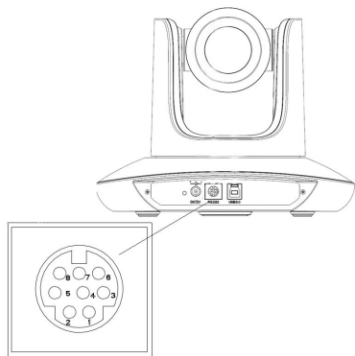

No.	Function
1	DTR
2	DSR
3	TXD
4	GND
5	RXD
6	A
7	IR OUT
8	B

### VISCA IN & DB9 Connection

Camera VISCA IN		Windows DB-9	
1	DTR	6	DSR
2	DSR	4	DTR
3	TXD	2	RXD
4	GND	5	GND
5	RXD	3	TXD
6	A(+)		
7	IR OUT		
8	B(-)		

### VISCA IN & RS485 Connection

Camera VISCA IN		RS485
1	DTR	
2	DSR	
3	TXD	
4	GND	GND
5	RXD	
6	A(+)	A(+)
7	IR OUT	
8	B(-)	B(-)

### SERIAL PORT CONFIGURATION:

Parameter	Value	Parameter	Value
Baud rate	2400/4800/9600/115200	Stop Bit	1bit
Start Bit	1 bit	Verify Bit	None
Date Bit	8 bit		

# VISCA PROTOCOL

## Part1 Camera Return Command

Ack/Completion Message		
	Command Packet	Note
ACK	z0 41 FF	Returned when the command is accepted.
Completion	z0 51 FF	Returned when the command has been executed.

z = camera address+8

Error Messages		
	Command Packet	Note
Syntax Error	z0 60 02 FF	Returned when the command format is different or when a command with illegal command parameters is accepted
Command Not Executable	z0 61 41 FF	Returned when a command cannot be executed due to current conditions. For example, when commands controlling the focus manually are received during auto focus.

## Part2 Camera Control Command

Command	Function	Command Packet	Note
AddressSet	Broadcast	88 30 01 FF	Address setting
IF_Clear	Broadcast	88 01 00 01 FF	I/F Clear
CAM_Power	On	8x 01 04 00 02 FF	Power ON/OFF
	Off	8x 01 04 00 03 FF	
CAM_Zoom	Stop	8x 01 04 07 00 FF	p = 0(low)~7(high)
	Tele(Standard)	8x 01 04 07 02 FF	
	Wide(Standard)	8x 01 04 07 03 FF	
	Tele(Variable)	8x 01 04 07 2p FF	
	Wide(Variable)	8x 01 04 07 3p FF	
	Direct	8x 01 04 47 0p 0q 0r 0s FF	
CAM_Focus	Stop	8x 01 04 08 00 FF	pqrs: Focus Position
	Far(Standard)	8x 01 04 08 02 FF	
	Near(Standard)	8x 01 04 08 03 FF	
	Direct	8x 01 04 48 0p 0q 0r 0s FF	
	One Push AF	8x 01 04 18 01 FF	
CAM_ZoomFocus	Direct	8x 01 04 47 0p 0q 0r 0s 0t 0u 0v 0w FF	pqrs: Zoom Position (0(wide)~ 0x4000(tele)) tuwv: Focus Position
CAM_WB	Auto	8x 01 04 35 00 FF	
	Indoor	8x 01 04 35 01 FF	
	Outdoor	8x 01 04 35 02 FF	

Command	Function	Command Packet	Note
	OnePush	8x 01 04 35 03 FF	
	ATW	8x 01 04 35 04 FF	
	Manual	8x 01 04 35 05 FF	
	Sodium Lamp	8x 01 04 35 08 FF	
	Fluorescent lamp	8x 01 04 35 09 FF	
CAM_RGain	Reset	8x 01 04 03 00 FF	Manual Control of R Gain
	Up	8x 01 04 03 02 FF	
	Down	8x 01 04 03 03 FF	
	Direct	8x 01 04 43 00 00 0p 0q FF	pq: R Gain (0~0xFF)
CAM_Bgain	Reset	8x 01 04 04 00 FF	Manual Control of B Gain
	Up	8x 01 04 04 02 FF	
	Down	8x 01 04 04 03 FF	
	Direct	8x 01 04 44 00 00 0p 0q FF	pq: B Gain (0~0xFF)
CAM_AE	Full Auto	8x 01 04 39 00 FF	Automatic Exposure mode
	Manual	8x 01 04 39 03 FF	Manual Control mode
	Shutter Priority	8x 01 04 39 0A FF	Shutter Priority mode
	Iris Priority	8x 01 04 39 0B FF	Iris Priority mode
	Bright	8x 01 04 39 0D FF	Bright mode(Manual control)
CAM_Shutter	Reset	8x 01 04 0A 00 FF	Shutter Setting
	Up	8x 01 04 0A 02 FF	
	Down	8x 01 04 0A 03 FF	
	Direct	8x 01 04 4A 00 00 0p 0q FF	pq: Shutter Position (0~0x15)
CAM_Iris	Reset	8x 01 04 0B 00 FF	Iris Setting
	Up	8x 01 04 0B 02 FF	
	Down	8x 01 04 0B 03 FF	
	Direct	8x 01 04 4B 00 00 0p 0q FF	pq: Iris Position (0~ 0x11)
CAM_Gain	Reset	8x 01 04 0C 00 FF	Gain Setting
	Up	8x 01 04 0C 02 FF	
	Down	8x 01 04 0C 03 FF	
	Direct	8x 01 04 0C 00 00 0p 0q FF	pq: Gain Positon (0~0x0E)
CAM_Bright	Reset	8x 01 04 0D 00 FF	Bright Setting
	Up	8x 01 04 0D 02 FF	
	Down	8x 01 04 0D 03 FF	
	Direct	8x 01 04 4D 00 00 0p 0q FF	pq: Bright I Positon ( )

Command	Function	Command Packet	Note
CAM_WDR	On	8x 01 04 3D 02 FF	WDR ON/OFF
	Off	8x 01 04 3D 03 FF	
	Direct	8x 01 04 D3 0p FF	pq: WDR Position (1~0x06)
CAM_BackLight	On	8x 01 04 33 02 FF	BackLight On
	Off	8x 01 04 33 03 FF	BackLight Off
CAM_Sharpness	Reset	8x 01 04 02 00 FF	Sharpness Control
	Up	8x 01 04 02 02 FF	
	Down	8x 01 04 02 03 FF	
	Direct	8x 01 04 42 00 0p 0q FF	pq: Aperture Gain (0~0x04)
CAM_Preset	Reset	8x 01 04 3F 00 0p FF	p: Preset Number(=0 to 127) Corresponds to 0 to 9 on the Remote Commander
	Set	8x 01 04 3F 01 0p FF	
	Recall	8x 01 04 3F 02 0p FF	
CAM_LR_Reverse	On	8x 01 04 61 02 FF	Image Flip Horizontal ON/OFF
	Off	8x 01 04 61 03 FF	
CAM_PictureFlip	On	8x 01 04 66 02 FF	Image Flip Vertical ON/OFF
	Off	8x 01 04 66 03 FF	
CAM_MountMode	UP	8x 01 04 A4 02 FF	Mount Up
	Down	8x 01 04 A4 03 FF	Mount Down
CAM_ColorGain	Direct	8x 01 04 49 00 00 0p FF	(0~0x0E)
CAM_Saturation	Direct	8x 01 04 A1 00 00 0p FF	(0~0x0E)
CAM_2D Noise Reduction	Direct	8x 01 04 53 0p FF	(0~0x05)
CAM_3D Noise Reduction	Direct	8x 01 04 54 0p FF	(0~0x03)
CAM_NewBright	Direct	81 01 04 A4 00 00 0p 0q FF	(0~0x0F)
CAM_Constrast	Direct	81 01 04 A2 00 00 0p 0q FF	(0~0x0F)
CAM_Gamma	Direct	8x 01 04 5B 0p FF	(0~0x04)
FLICK	Off	81 01 04 23 00 FF	
	50HZ	81 01 04 23 01 FF	
	60HZ	81 01 04 23 02 FF	
SYS_Menu	Menu On	8x 01 06 06 02 FF	Turn on the menu
	Menu Off	8x 01 06 06 03 FF	Turn off the menu
	Menu Back	8x 01 06 06 10 FF	Menu step back
	Menu Ok	8x 01 7E 01 02 00 01 FF	Menu ok
IR_Transfer	Transfer On	8x 01 06 1A 02 FF	Receive IR(remote commander) CODE from VISCA communication ON/OFF
	Transfer Off	8x 01 06 1A 03 FF	

Command	Function	Command Packet	Note
IR_Receive	On	8x 01 06 08 02 FF	IR(remote commander)receive ON/OFF
	Off	8x 01 06 08 03 FF	
	On/Off	8x 01 06 08 10 FF	
IR_ReceiveReturn	On	8x 01 7D 01 03 00 00 FF	IR(remote commander)receive message via the VISCA communication ON/OFF
	Off	8x 01 7D 01 13 00 00 FF	
Pan_tiltDrive	Up	8x 01 06 01 VV WW 03 01 FF	VV: Pan speed 0x01 (low speed) to 0x18 (high speed) WW: Tilt speed 0x01 (low speed) to 0x14 (high speed) YYYY: Pan Position(TBD) ZZZZ: Tilt Position(TBD)
	Down	8x 01 06 01 VV WW 03 02 FF	
	Left	8x 01 06 01 VV WW 01 03 FF	
	Right	8x 01 06 01 VV WW 02 03 FF	
	Upleft	8x 01 06 01 VV WW 01 01 FF	
	Upright	8x 01 06 01 VV WW 02 01 FF	
	DownLeft	8x 01 06 01 VV WW 01 02 FF	
	DownRight	8x 01 06 01 VV WW 02 02 FF	
	Stop	8x 01 06 01 VV WW 03 03 FF	
	AbsolutePosition	8x 01 06 02 VV WW 0Y 0Y 0Y 0Y 0Z 0Z 0Z 0Z FF	
	RelativePosition	8x 01 06 03 VV WW 0Y 0Y 0Y 0Y 0Z 0Z 0Z 0Z FF	
	Home	8x 01 06 04 FF	
Reset	8x 01 06 05 FF		
Pan-tiltLimitSet	Set	8x 01 06 07 00 0W 0Y 0Y 0Y 0Y 0Z 0Z 0Z 0Z FF	W:1 UpRight 0:DownLeft YYYY: Pan Limit Position(TBD) ZZZZ: Tilt Limit Position(TBD)
	Clear	8x 01 06 07 01 0W 07 0F 0F 0F 07 0F 0F 0F FF	

### Part3 Inquiry Command

Command	Command Packet	Return Packet	Note
CAM_PowerInq	8x 09 04 00 FF	y0 50 02 FF	On
		y0 50 03 FF	Off(Standby)
CAM_ZoomPosInq	8x 09 04 47 FF	y0 50 0p 0q 0r 0s FF	pqrs: Zoom Position
CAM_FocusModelInq	8x 09 04 38 FF	y0 50 02 FF	Auto Focus
		y0 50 03 FF	Manual Focus
CAM_FocusPosInq	8x 09 04 48 FF	y0 50 0p 0q 0r 0s FF	pqrs: Focus Position
CAM_WBModelInq	8x 09 04 35 FF	y0 50 00 FF	Auto
		y0 50 01 FF	Indoor mode
		y0 50 02 FF	Outdoor mode
		y0 50 03 FF	OnePush mode
		y0 50 04 FF	ATW
		y0 50 05 FF	Manual
CAM_RGainInq	8x 09 04 43 FF	y0 50 00 00 0p 0q FF	pq: R Gain

CAM_BGainInq	8x 09 04 44 FF	y0 50 00 00 0p 0q FF	pq: B Gain
CAM_AEModeInq	8x 09 04 39 FF	y0 50 00 FF	Full Auto
		y0 50 03 FF	Manual
		y0 50 0A FF	Shutter priority
		y0 50 0B FF	Iris priority
		y0 50 0D FF	Bright
CAM_ShutterPosInq	8x 09 04 4A FF	y0 50 00 00 0p 0q FF	pq: Shutter Position
CAM_IrisPosInq	8x 09 04 4B FF	y0 50 00 00 0p 0q FF	pq: Iris Position
CAM_GainPosInq	8x 09 04 4C FF	y0 50 00 00 0p 0q FF	pq: Gain Position
CAM_BrightPosInq	8x 09 04 4D FF	y0 50 00 00 0p 0q FF	pq: Bright Position
CAM_ExpCompModelInq	8x 09 04 3E FF	y0 50 02 FF	On
		y0 50 03 FF	Off
CAM_ExpCompPosInq	8x 09 04 4E FF	y0 50 00 00 0p 0q FF	pq: ExpComp Position
CAM_ApertureInq	8x 09 04 42 FF	y0 50 00 00 0p 0q FF	pq: Aperture Gain
CAM_MemoryInq	8x 09 04 3F FF	y0 50pp FF	pp: Memory number last operated.
SYS_MenuModelInq	8x 09 06 06 FF	y0 50 02 FF	On
		y0 50 03 FF	Off
CAM_LR_ReverseInq	8x 09 04 61 FF	y0 50 02 FF	On
		y0 50 03 FF	Off
CAM_PictureFlipInq	8x 09 04 66 FF	y0 50 02 FF	On
		y0 50 03 FF	Off
CAM_VersionInq	8x 09 00 02 FF	y0 50 ab cd mn pq rs tu vw FF	
IR_Transfer	8x 09 06 1A FF	y0 50 02 FF	On
		y0 50 03 FF	Off
IR_Receive	8x 09 06 08 FF	y0 50 02 FF	On
		y0 50 03 FF	Off
IR_ReceiveReturn		y0 07 7D 01 04 00 FF	Power ON/OFF
		y0 07 7D 01 04 07 FF	Zoom tele/wide
		y0 07 7D 01 04 38 FF	AF On/Off
		y0 07 7D 01 04 33 FF	CAM_Backlight
		y0 07 7D 01 04 3F FF	CAM_Memory
Pan-tiltPosInq	8x 09 06 12 FF	y0 50 0w 0w 0w 0w 0z 0z 0z 0z FF	www: PanPosition    zzzz: Tilt Position

**Note:** **【x】** means the camera address ; **【y】** = **【x + 8】** .

#### VISCA PAN TILT ABSOLUTE POSITION VALUE

Pan Angle	VISCA Value	Tilt Angle	VISCA Value
-170	0xF670	-30	0xFE50
-135	0xF868	0	0x0000
-90	0xFAF0	30	0x0180
-45	0xFD78	60	0x0360
0	0x0000	90	0x510
45	0x0288		
90	0x0510		
135	0x0798		
170	0x0990		



**EXPOSURE DATA SHEET**

		60/30mode	50/25mode			
Shutter speed	15	1/10000	1/10000	Iris	0	close
	14	1/6000	1/6000		1	F14
	13	1/4000	1/3500		2	F11
	12	1/3000	1/2500		3	F9.6
	11	1/2000	1/1750		4	F8
	10	1/1500	1/1250		5	F6.8
	0F	1/1000	1/1000		6	F5.6
	0E	1/725	1/600		7	F4.8
	0D	1/500	1/425		8	F4
	0C	1/350	1/300		9	F3.4
	0B	1/250	1/215		10	F2.8
	0A	1/180	1/150		11	F2.4
	09	1/125	1/120		12	F2
	08	1/100	1/100		13	F1.8
	07	1/90	1/75			
	06	1/60	1/50			
	05	1/30	1/25			
	04	1/15	1/12			
	03	1/8	1/6			
	02	1/4	1/3			
01	1/2	1/2				
00	1/1	1/1				
Gain	0	0dB		Gain	8	16dB
	1	2dB			9	18dB
	2	4dB			10	20dB
	3	6dB			11	22dB
	4	8dB			12	24dB
	5	10dB			13	26dB
	6	12dB			14	28dB
	7	14dB			15	30dB

Bright		IRIS	GAIN
	1B	F1.8	+28 dB
	1A	F1.8	+26 dB
	19	F1.8	+24 dB
	18	F1.8	+22 dB
	17	F1.8	+20 dB
	16	F1.8	+18 dB
	15	F1.8	+16 dB
	14	F1.8	+14 dB
	13	F1.8	+12 dB
	12	F1.8	+10 dB
	11	F1.8	+8 dB
	10	F1.8	+6 dB
	0F	F1.8	+4 dB
	0E	F1.8	+2 dB
	0D	F1.8	0 dB
	0C	F2	0 dB
	0B	F2.4	0 dB
	0A	F2.8	0 dB
	09	F3.4	0 dB
08	F4	0 dB	
07	F4.8	0 dB	
06	F5.6	0 dB	
05	F6.8	0 dB	
04	F8	0 dB	
03	F9.6	0 dB	
02	F11	0 dB	
01	F14	0 dB	
00	CLOSE	0 dB	

## PELCO-D PROTOCOL

Function	Byte1	Byte2	Byte3	Byte4	Byte5	Byte6	Byte7
Up	0xFF	Address	0x00	0x08	Pan Speed	Tilt Speed	SUM
Down	0xFF	Address	0x00	0x10	Pan Speed	Tilt Speed	SUM
Left	0xFF	Address	0x00	0x04	Pan Speed	Tilt Speed	SUM
Right	0xFF	Address	0x00	0x02	Pan Speed	Tilt Speed	SUM
Upleft	0xFF	Address	0x00	0x0C	Pan Speed	Tilt Speed	SUM
Upright	0xFF	Address	0x00	0x0A	Pan Speed	Tilt Speed	SUM
DownLeft	0xFF	Address	0x00	0x14	Pan Speed	Tilt Speed	SUM
DownRight	0xFF	Address	0x00	0x12	Pan Speed	Tilt Speed	SUM
Zoom In	0xFF	Address	0x00	0x20	0x00	0x00	SUM
Zoom Out	0xFF	Address	0x00	0x40	0x00	0x00	SUM
Focus Far	0xFF	Address	0x00	0x80	0x00	0x00	SUM
Focus Near	0xFF	Address	0x01	0x00	0x00	0x00	SUM
Set Preset	0xFF	Address	0x00	0x03	0x00	Preset ID	SUM
Clear Preset	0xFF	Address	0x00	0x05	0x00	Preset ID	SUM
Call Preset	0xFF	Address	0x00	0x07	0x00	Preset ID	SUM
Query Pan Position	0xFF	Address	0x00	0x51	0x00	0x00	SUM
Query Pan Position Response	0xFF	Address	0x00	0x59	Value High Byte	Value Low Byte	SUM
Query Tilt Position	0xFF	Address	0x00	0x53	0x00	0x00	SUM
Query Tilt Position Response	0xFF	Address	0x00	0x5B	Value High Byte	Value Low Byte	SUM
Query Zoom Position	0xFF	Address	0x00	0x55	0x00	0x00	SUM
Query Zoom Position Response	0xFF	Address	0x00	0x5D	Value High Byte	Value Low Byte	SUM

## PELCO-P PROTOCOL

Function	Byte1	Byte2	Byte3	Byte4	Byte5	Byte6	Byte7	Byte8
Up	0xA0	Address	0x00	0x08	Pan Speed	Tilt Speed	0xAF	XOR
Down	0xA0	Address	0x00	0x10	Pan Speed	Tilt Speed	0xAF	XOR
Left	0xA0	Address	0x00	0x04	Pan Speed	Tilt Speed	0xAF	XOR
Right	0xA0	Address	0x00	0x02	Pan Speed	Tilt Speed	0xAF	XOR
Upleft	0xA0	Address	0x00	0x0C	Pan Speed	Tilt Speed	0xAF	XOR
Upright	0xA0	Address	0x00	0x0A	Pan Speed	Tilt Speed	0xAF	XOR
DownLeft	0xA0	Address	0x00	0x14	Pan Speed	Tilt Speed	0xAF	XOR
DownRight	0xA0	Address	0x00	0x12	Pan Speed	Tilt Speed	0xAF	XOR
Zoom In	0xA0	Address	0x00	0x20	0x00	0x00	0xAF	XOR
Zoom Out	0xA0	Address	0x00	0x40	0x00	0x00	0xAF	XOR
Focus Far	0xA0	Address	0x00	0x80	0x00	0x00	0xAF	XOR
Focus Near	0xA0	Address	0x01	0x00	0x00	0x00	0xAF	XOR
Set Preset	0xA0	Address	0x00	0x03	0x00	Preset ID	0xAF	XOR
Clear Preset	0xA0	Address	0x00	0x05	0x00	Preset ID	0xAF	XOR
Call Preset	0xA0	Address	0x00	0x07	0x00	Preset ID	0xAF	XOR
Query Pan Position	0xA0	Address	0x00	0x51	0x00	0x00	0xAF	XOR
Query Pan Position Response	0xA0	Address	0x00	0x59	Value High Byte	Value Low Byte	0xAF	XOR
Query Tilt Position	0xA0	Address	0x00	0x53	0x00	0x00	0xAF	XOR
Query Tilt Position Response	0xA0	Address	0x00	0x5B	Value High Byte	Value Low Byte	0xAF	XOR
Query Zoom Position	0xA0	Address	0x00	0x55	0x00	0x00	0xAF	XOR
Query Zoom Position Response	0xA0	Address	0x00	0x5D	Value High Byte	Value Low Byte	0xAF	XOR

## OSD MENU

1. under working mode, press the menu button on the IR remote, to enter the OSD menu ;



2. Use the navigate button to select the main menu. Once been selected, the main menu will change to blue color background, and the right side will show all parameters under this sub menu :

3. Press the right navigate button to enter sub menu, use up and down navigate button to select parameter;



4. Press the menu button again to return to previous menu; Press it continuously to exit the OSD menu.

Before exiting, will show up a window to remind whether need to save all settings( use left and right button to set)



### 5.OSD Menu Setting List

SYSTEM	LANGUAGE	ENGLISH/CHINESE	Defaulted: English
	PROTOCOL	VISCA/PELCO-P/PELCO-D	Defaulted: VISCA
	ADDRESS	VISCA:1~7      PELCO-P/D:0~255	Defaulted: 1
	BAUDRATE	2400/4800/9600/115200	Defaulted: 9600
	RETURN	Back to Main Menu	

FOCUS	FOCUS MODE	AUTO, MANUAL/PUSH	Defaulted: AUTO
	FOCUS LIMIT	Focus Distance between camera and the object: 1.5M/2M/3M/6M/10M	Defaulted:1.5M
	DZOOM	DIGITAL ZOOM: ON/OFF	Defaulted: OFF
	RATIO DIS	Zoom Rate Display (include Digital Zoom): ON/OFF	Defaulted: OFF
	RETURN	Back to Main Menu	

EXPOSURE	EXP. MODE	Exposure Mode: AUTO/MANUAL/BRIGHT/SHUTTER/IRIS	Defaulted: AUTO
	SHUTTER	Shutter Speed:1/8~1/10000, Only valid when EXP MODE set to MANUAL or SHUTTER mode	Defaulted: 1/100
	IRIS	Iris Setting: CLOSE~F1.8, Only valid when the EXP MODE set to MANUAL or IRIS mode	Defaulted:10
	GAIN	Gain Setting: 0dB~28dB Only valid when the EXP MODE set to MANUAL mode	Defaulted:0
	BRIGHT	Brightness Setting: 0~15 Only valid when the EXP MODE set to MANUAL mode	Defaulted:11
	FLICK	Anti-Flicker Setting: OFF/50Hz/60Hz	Defaulted: 50Hz
	BACKLIGHT	OFF/ON	Defaulted: OFF
	GAMMA	Gamma Setting: 0~4	Defaulted: 0
RETURN	Back to Main Menu		

IMAGE	WB MODE	White Balance Setting: ATW(Auto White Balance), MANU(Manual), MANU2(Manual2), SON.(Sodium Lamp), FL(Fluorescent Lamp), AUTO, IDR.(In Door), ODR.(Out Door), PUSH	Defaulted: AUTO
	R_GAIN	Red Gain Setting: 0~255, Only valid when WB MODE set to MANUAL mode	Defaulted: 58
	B_GAIN	Blue Gain Setting: 0~255, Only valid when WB MODE set to MANUAL mode	Defaulted: 52
	DEFOG	Image Transparency Setting: OFF/1~15	Defaulted: 0
	RETURN	Back to Main Menu	

QUALITY	2D NR	2D Noise Reduction: OFF/ON	Defaulted: OFF
	3D NR	3D Noise Reduction: OFF/AUTO/1~4	Defaulted:AUTO
	SHARPNESS	Sharpness Setting: OFF/0~15	Defaulted: OFF
	CONTRAST	Contrast Setting: 0~15	Defaulted: 8
	SATURATION	Color Saturation Setting: 0~15	Defaulted:8
	BRIGHT	Brightness Setting: 0~15	Defaulted:6
	D_WDR	Wide Dynamic Rate: OFF/1~6	Defaulted: On
	RETURN	Back to Main Menu	

CTRL	MIRROR	Image 180degree rotation left/right: OFF/ON	Defaulted: OFF
	FLIP	Image 180degree rotation up/down: OFF/ON	Defaulted: OFF
	D/N MODE	DAY/NIGHT	Defaulted: DAY
	GAIN LIMIT	Gain limit value setting	Defaulted: 128
	RETURN	Back to Main Menu	

VIDEO FORMAT	1080P60	720P60	1024x576@30	Only for display current video format, can't switch video format via OSD.
	1080P50	720P50	960x540@30	
	1080P30	720P30	640x360@30	
	1080P25	720P25	352x288@30	

RESET	CAM RESET	Camera Reset
	PTZ RESET	Pan Tilt Zoom Reset
	ALL RESET	All Reset
	RETURN	Back to Main Menu

INFO	CONTROL VE	Camera Control Firmware Version
	CONTROL DA	Camera Control Firmware Release Date
	FORMAT	Current Video Format
	BAUDRATE	Current Baud Rate
	RETURN	Back to Main Menu

## IR TRANSFER(IR PASS)

1. Currently the camera support NEC code format. For customized with other codes, pls contact us.
2. Once the camera finish power configuration, enable the IR transfer function via sending COM command.
3. Get the targeted remote controller point to the camera IR receiver, press keys on the remote controller, then the camera will output the received IR code via VISCA IN port.
4. IR Transfer output format: XX XX XX XX\_FF

XX XX XX XX: Remote Controller Code

FF: End Code

## UVC CONTROL

1. Only run the client software after the USB3.0 camera has completed self-configuration (the IR indicator in blue color and will not flash); otherwise may cause black video issue.
2. Make sure the USB3.0 camera is recognized by the PC Device Manager.
3. Make sure the interval of video format switching more than 1 second, otherwise black video may be caused.
4. Make sure the interval of control command sending from the server (via USB) to the camera no less than 250ms.
5. Support standard UVC interface..

UVC Property	Corresponded VISCA Command
PU_BACKLIGHT_COMPENSATION_CONTROL	8x 01 04 33 02 FF
CY_FX_UVC_PU_BRIGHTNESS_CONTROL	8x 01 04 A4 00 00 0p 0q FF
CY_FX_UVC_PU_CONTRAST_CONTROL	8x 01 04 A2 00 00 0p 0q FF
CY_FX_UVC_PU_SATURATION_CONTROL	8x 01 04 A1 00 00 0p 0q FF
CY_FX_UVC_PU_SHARPNESS_CONTROL	8x 01 04 42 00 00 0p 0q FF
CY_FX_UVC_PU_GAMMA_CONTROL	8x 01 04 5B 0p FF
CY_FX_UVC_PU_WHITE_BALANCE_TEMPERATURE_CONTROL	8x 01 04 35 0p FF
CY_FX_UVC_PU_BACKLIGHT_COMPENSATION_CONTROL	8x 01 04 33 0p FF
CY_FX_UVC_PU_GAIN_CONTROL	8x 01 04 49 00 00 0p 0q FF
CY_FX_UVC_PU_POWER_LINE_FREQUENCY_CONTROL	8x 01 04 AA 0p FF
PU_GAIN_CONTROL	8x 01 04 49 00 00 00 0p FF
CT_ZOOM_ABSOLUTE_CONTROL	8x 01 04 47 0p 0q 0r 0s FF
CT_PANTILT_ABSOLUTE_CONTROL	8x 01 06 02 VV WW 0Y 0Y 0Y 0Z 0Z 0Z 0Z F
CT_PANTILT_RELATIVE_CONTROL	8x 01 06 01 pp qq rr ss FF
CT_ZOOM_RELATIVE_CONTROL	8x 01 04 07 pp FF